



Important:

Instructions for installation of Ring & Pinion sets.

We highly recommend that you read this set of instructions completely before beginning the installation of this new gear set. Correct installation can be the difference in a safe extended gear life... or premature failure.

1. Remove the old gear set and thoroughly clean both the ring gear carrier and rear end housing with solvent. After cleaning, air dry all parts.
2. Always verify you have the correct gear ratio that you have purchased. This can be checked by dividing ring gear tooth count by the pinion tooth count.

EG. RING GEAR TOOTH COUNT - 35T
PINION GEAR TOOTH COUNT - 10T

$$35 \div 10 = 3.50:1$$

3. Most differential cases have many thousands of miles of service. Check all threads in the case for wear. It may be necessary to run an engineering tap to chase, clean, and align threads.
4. Check side bearing adjusters as they are often warped and out of shape making ring and pinion settings difficult. Replace as necessary.
5. Check ring gear back face for flatness. Generally after heat treating there may be a degree of taper. This may be rectified by lapping the gear with sand paper on a glass flat plate. This will give you a more even and uniform pattern when setting up your new gear set.
6. Careful attention should be given to blueprinting your rear end. Accurate clearancing will lead to a longer life for your unit.
7. All new parts should be thoroughly cleaned before assembly, and checked for damage.
8. Examine the ring gear mounting surface for nicks or burrs which might prevent a flush mounting of the newly installed ring gear. Ring/Pinion tooth depth variations can result from a ring gear that is "cocked" on its mounting surface. If a ring gear spacer is to be used, also check it for surface imperfections. Nicks or burrs can be removed by using block-backed grit paper or a small file. Following material removal, rewash in solvent and air dry. Mount ring gear. Loctite ring gear bolts and torque to factory specifications.
9. All ring gear and pinions have been "Lapped" in sets and should never be mixed with another ring gear or pinion. Check to see serial numbers are the same on the ring gear and pinion.
10. Each ring gear and pinion is pre-run and marked on the pinion face with its proper depth setting called the "Checking Distance." This dimension is from the face of the pinion to the axle center-line. A setting tool must be used to measure the checking distance. Pinion depth is adjusted by adding or subtracting shim thickness. Stay +/- .002 of the pinion dimension, (See illustrations 'A' and 'B').
11. Once pinion depth is achieved using a new crush collar or preload shim, pack pinion bearing preload to 15 inch-pounds rotating torque with used bearings, and 25 inch-pounds with new bearings. Once preload is set, install the seal and loctite pinion nut.
12. Once the pinion gear is installed, position ring gear and carrier into housing to check backlash. Ring and pinions are developed to be run at .008" to .012" backlash for street gear sets.
13. Adjustments for backlash is done by spanner rings in the housing or shim packs behind the carrier bearing cups (G.M.) or cones (Dana). Always be sure carrier bearings are preloaded. The carrier should not fall out of the housing, but should have to be "tapped" in during final installation. Replace bearing caps and torque to factory specifications.
14. You are now ready to verify the tooth contact pattern. A gear marking compound should be used. Paint gear teeth with compound in several spots and rotate ring gear several revolutions. A tooth contact pattern will appear and should be similar to the pattern shown in illustration 'C'. If the pattern is not in the approximate position shown, reset pinion depth and backlash to correct pattern. Pinion shims usually must be moved in .003 of an inch increments to notice a pattern change. If a pattern is heavy toe subtract shims, (See Illustration D). If a pattern is heavy heel add shims, (See Illustration E).

NOTE: Reverse this procedure for 8" and 9" Ford.

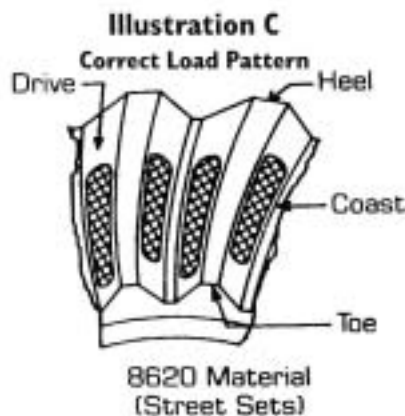
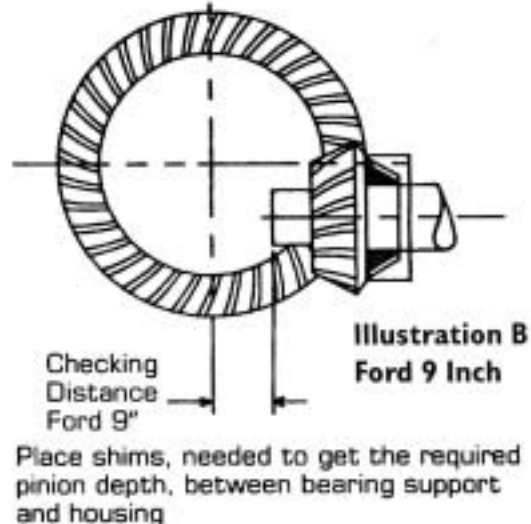
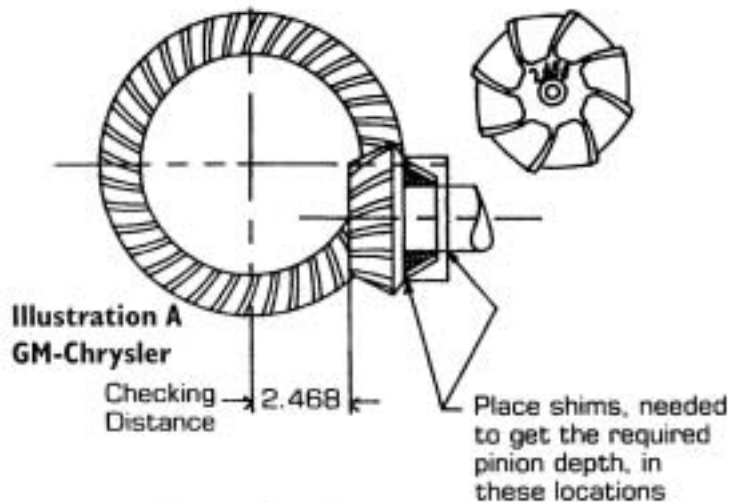

15. Fill the case with required amount of EP85-90 gear lube, and maintain the proper level at all times. Proper maintenance is a must to protect your safety and the working life of your gear set.

LIMITED WARRANTY

NOTICE: Manufacturer's obligation for warranty returns shall be limited to repairing, or replacing, or crediting at its option, any parts found to be defective. Manufacturer will not be liable for charges and/or other expenses incurred, nor shall it be liable for damages or injury to persons or property resulting from the misuse or improper installation of any part subject to this warranty. The warranty contained herein is expressly in lieu of any and all other warranties, including any implied warranty of merchantability or fitness for any particular purpose.

NO PARTS WARRANTY ON COMPETITION APPLICATIONS

Competition parts are sold "as is" without any warranty whatsoever. Implied warranties, including warranties of merchantability or fitness for a particular purpose, are excluded. The entire risk as to the quality and performance of such parts is with the buyer. Should such parts prove

defective following their purchase, the buyer and not the manufacturer, distributor or retailer, assumes the entire cost of all necessary servicing or repair.

Parts warranties are voided if the part is used for competition or if they fail as a result of modification.

Torque Specifications

3/8" x 7/8" RH55-60 ft#
3/8" x 3/4" RH45-50 ft#
3/8" x ALL LH60-65 ft#
7/16" ALL60-65 ft#
1/2" ALL100-110 ft#

Carrier Cap Bolts

7/16" (5/8" head)60-65 ft#
1/2" (3/4" head)80-85 ft#

