



Panhard Mount

ALL56152

INSTALLATION INSTRUCTIONS

1. IMPORTANT! Before welding adjuster to chassis, use a 3/8" drive ratchet extension to turn adjusting screw and position slider as far away from welding heat as possible. This will protect the PTFE bushings from melting. Unit has 3" of screw adjustment.
2. To prevent damage of slider components, never exceed 30 foot-pounds of torque on adjuster screw.
3. To prevent binding of slider, never clamp adjustable panhard mount beyond retaining rings.
4. Keep light tension on nylon set screw to prevent screw from moving on its own.

OPTION 1

If upper tubing is directly over lower frame rail, holesaw through and weld to 1-3/4" tubing.

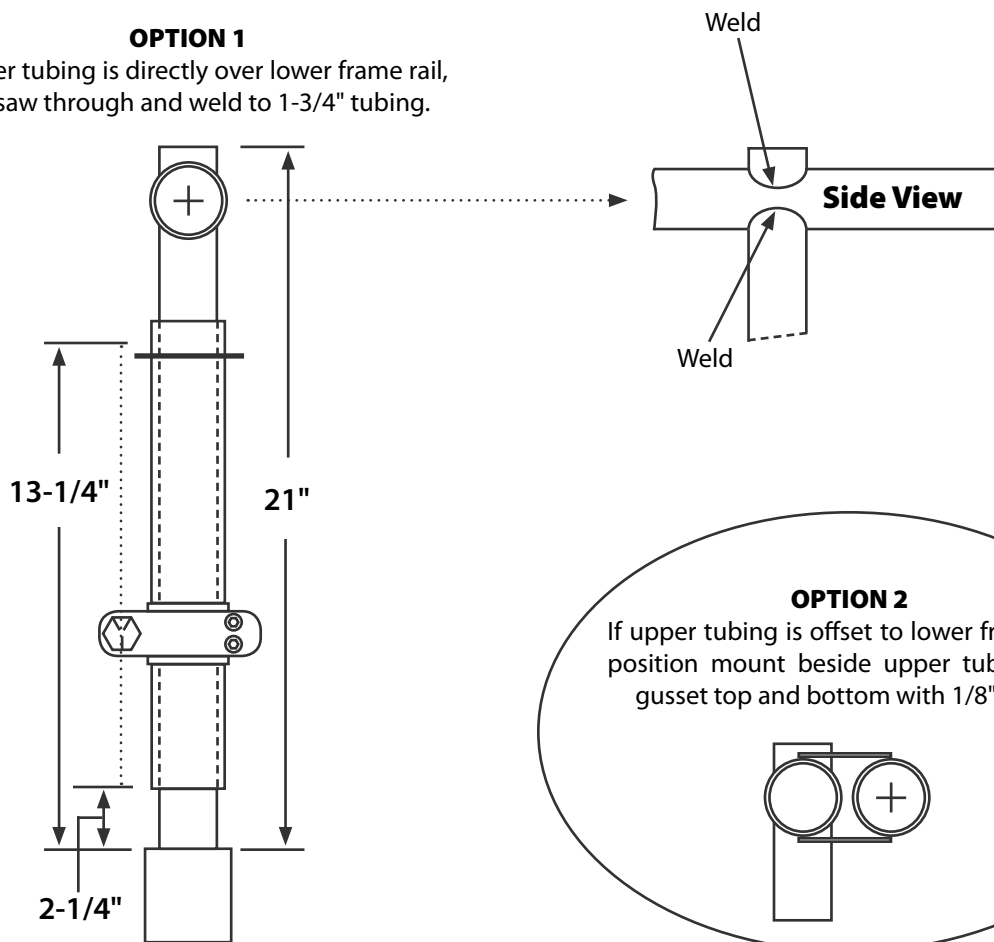

Front Mount

(unit accepts any 1-3/4" panhard clevis not included)

OPTION 2

If upper tubing is offset to lower frame rail, position mount beside upper tubing and gusset top and bottom with 1/8" plate.

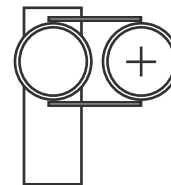

Allstar Performance 8300 Lane Dr., Watervliet, MI 49098

Phone: (269) 463-8000 Fax: (800) 772-2618 www.allstarperformance.com