



AEROMOTIVE®

**SERIOUS FUEL SYSTEMS
VOLUME 29**



Aeromotive Inc. is a true high performance manufacturer specializing in fuel delivery and fuel delivery components. Combining three generations of racing experience with ground-breaking innovation and aerospace manufacturing standards, Aeromotive delivers performance and quality that is second to none.

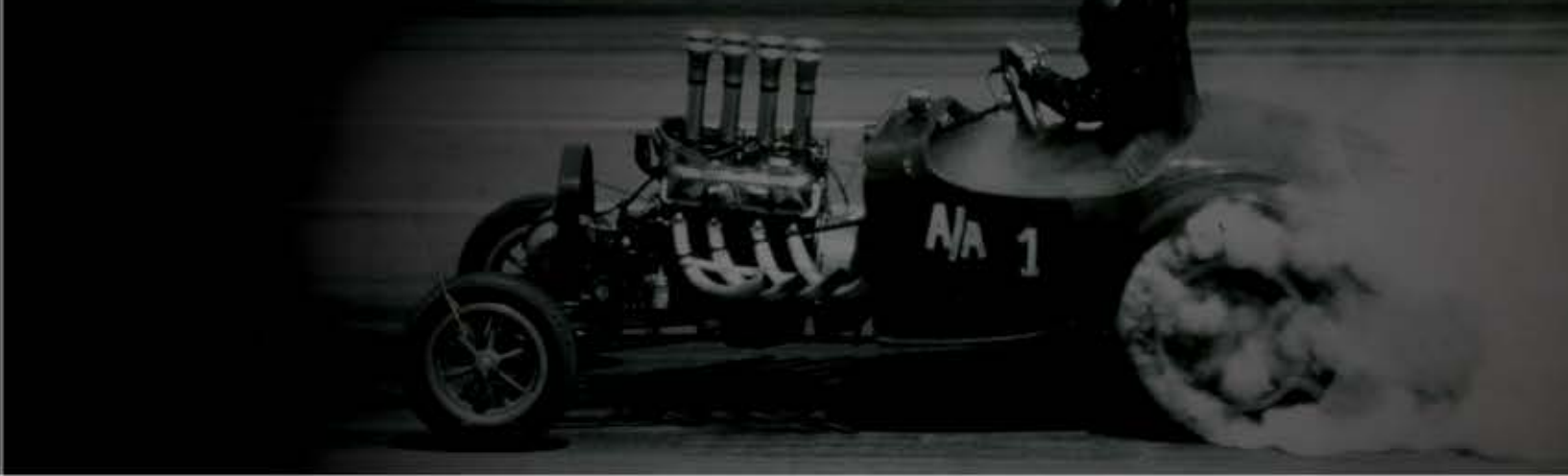

SERIOUS FUEL SYSTEMS

FOR THOSE WHO DEMAND MORE



Aeromotive has created a line of fuel system products that have become the absolute pinnacle of performance fuel delivery.



9x Recipient :
SEMA New Product Awards



INDEX

Products

- 2 - **Pumps**
 - External
 - Stealth
 - Mechanical
 - Diesel
- 22 - **Systems**
- 26 - **Regulators**
- 36 - **Filters**
- 39 - **Rails**
- 42 - **Accessories**

Power Planner



For more information on Aeromotive Inc., their extensive line of fuel delivery components, and the advantages they can provide, go to AeromotiveInc.com

Aeromotive is committed to providing the finest technical support in the industry.
To speak with one of their highly qualified technicians, call (913) 647-7300



PUMPS

Aerospace is not just a word to us, it's our history. Exacting tolerances, higher level processes and controls, exotic materials - it's no wonder we are the ONLY fuel system designer / manufacturer in the performance industry that can claim an aftermarket fuel pump that can support over 1,000 rear wheel horsepower and travel over 125,000 grueling street miles.

Performance, reliability, and durability are designed into every performance fuel pump that carries the AEROMOTIVE name. And, rest assured, EVERY pump is tested for flow at a prescribed pressure, current draw, and leakage. Once the pumps pass our test, then and only then do they get date-stamped and packaged, ready to quench the thirst of some of the hungriest beasts that roam our planet.

Whether its EFI or carbureted, nitrous-assisted, turbo-charged or blown, continuous duty or race only, you can be assured that there is a pump for you. One that maintains the level of quality you've come to expect from the company with the AEROSpace technology in the autoMOTIVE industry. It's all in our name AEROMOTIVE.

STEALTH

We know that the best place for a fuel pump is inside the fuel tank itself, submerged in fuel. By going in-tank, we eliminate many issues common in performance fuel systems. Whether it's hot fuel handling issues like cavitation and vapor-lock, or fuel slosh that uncovers the pick-up point or inlet of the fuel pump. This is the design of the Stealth Systems. Any Aeromotive product that bares the STEALTH badge is an "in-tank" fuel system.

The concept of the "in-tank" fuel system is not a new one. Government mandates forced OE automobile manufacturers to start down this path many years ago, but the performance requirements of those systems were nowhere near the demand of today's systems. As the performance demand increased, so did the need for fuel systems that could live up to the monster power numbers of which these new cars and engines were capable. Aeromotive strives to be on the leading edge of in-tank fuel systems.



Stealth Goes In Tank

FLOW CURVES

The key to selecting the right pump, is knowing exactly how it performs.

▲ 12 Volts

■ 13.5 Volts

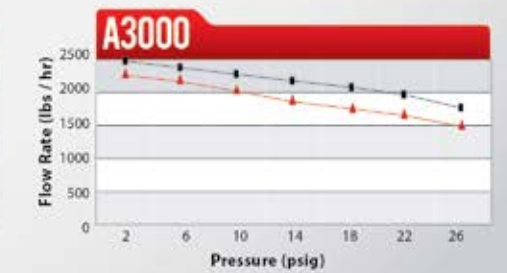
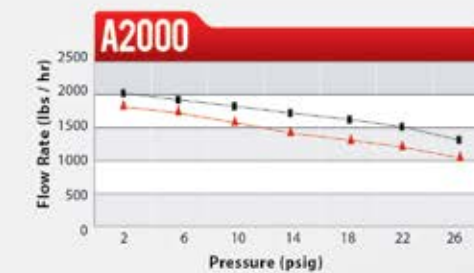
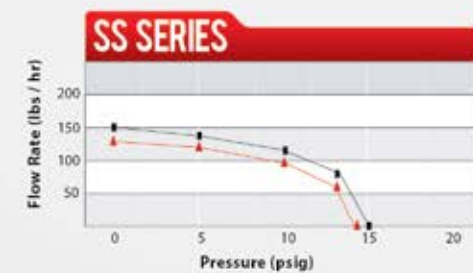
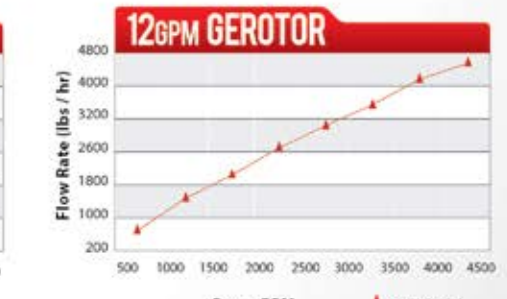
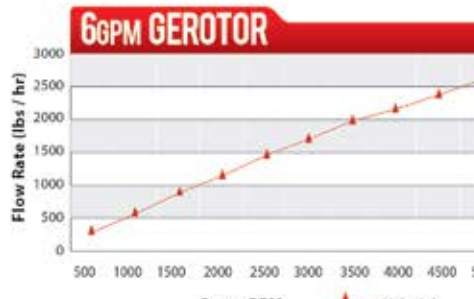
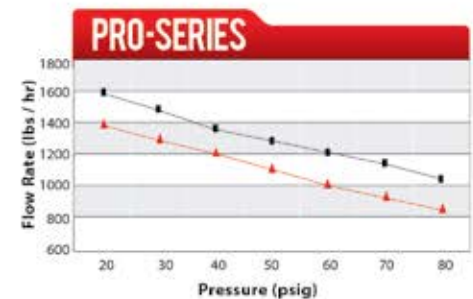
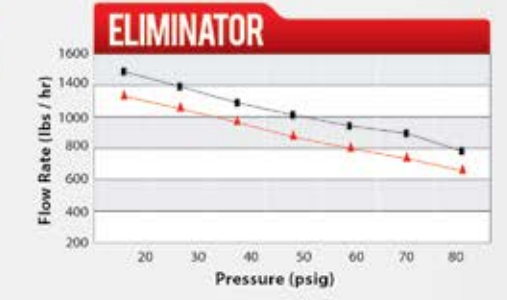
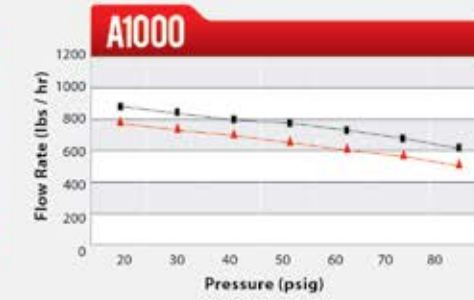
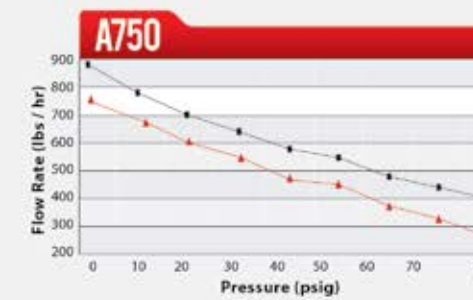
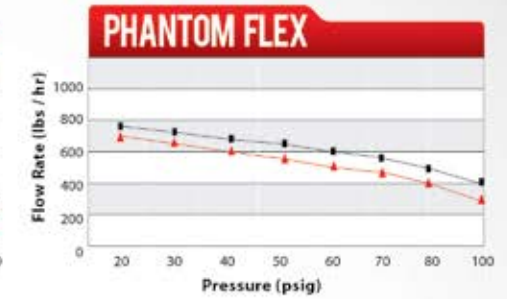
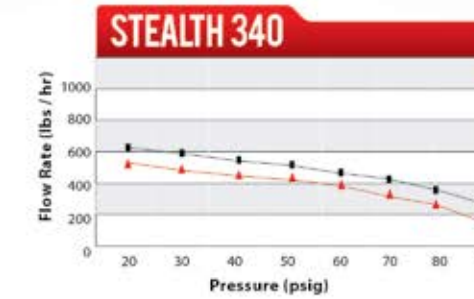
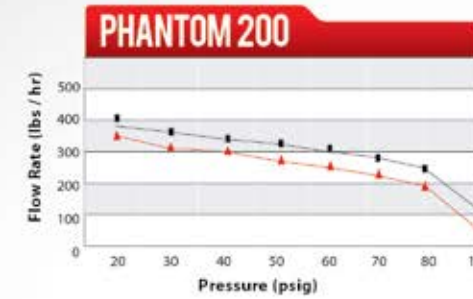

E85? It Takes More

It takes 30% more fuel to make the same power on E85. Multiply gas horsepower rating by 70% (.7) to find the appropriate horsepower rating for E85.

Example : 1,000hp Gas = 700hp E85

Products with the following label are safe for use with E85, Ethanol, Alcohol, and Methanol based fuels



E COMPATIBLE

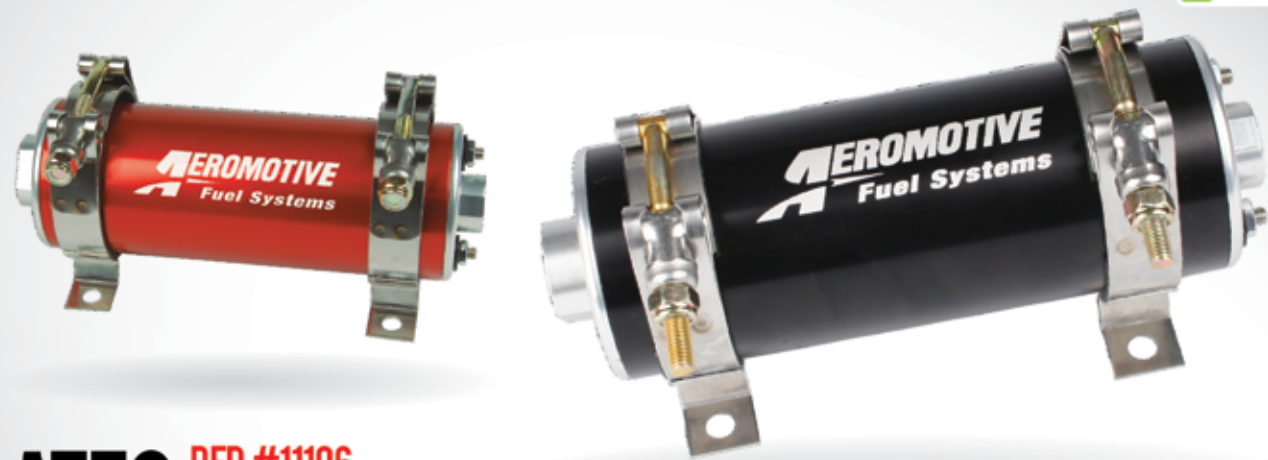

A750 RED #11106 BLACK #11103

Compact, quiet and durable, these billet, in-line pumps are ideal for low to medium HP applications. Perfect for street rods and muscle cars, fuel injected or carbureted.

- ORB-08 inlet ports and ORB-06 outlet ports.
- EFI applications use regulator #13129 or #13109.
- Carb applications use regulator #13204 or #13304.
- Fully submersible for custom, in-tank placement.

GAS	Naturally Aspirated	Forced Induction
Fuel Injected	800hp	600hp
Carbureted	1,000hp	800hp

E85	Naturally Aspirated	Forced Induction
Fuel Injected	560hp	420hp
Carbureted	700hp	560hp

EFI - 550lbs/hr 45psi 13.5v CARB - 700lbs/hr 8psi 13.5v

refer to flow charts on page 3 - system diagrams on page 53

E COMPATIBLE

ELIMINATOR #11104

This continuous duty "street warrior" supports more horsepower in a true street car than any other pump built. Designed for high horsepower street/strip applications, EFI or Carbureted, it features our "dual chamber" pumping mechanism.



- ORB-12 inlet port and ORB-10 outlet port.
- EFI applications use regulator #13134 or #13305
- Carbureted applications use regulator #13212 or #13202
- Fully submersible for custom, in-tank placement.
- 25% more flow at pressure than our A1000 Fuel Pump.
- Perfect for "blow-through" carbureted engines up to 1,700 HP.
- Speed Pump Controller (#16306) required for street applications.

Refer to this chart for all Eliminator Fuel Pumps, External and Stealth.

GAS	Naturally Aspirated	Forced Induction
Fuel Injected	1,900hp	1,400hp
Carbureted	2,300hp	1,700hp

E85	Naturally Aspirated	Forced Induction
Fuel Injected	1,330hp	980hp
Carbureted	1,610hp	1,190hp

EFI - 1000lbs/hr 45psi 13.5v CARB - 1300lbs/hr 8psi 13.5v

refer to flow charts on page 3 - system diagrams on page 54

E COMPATIBLE

A1000 #11101

This is the pump that started it all. Durable, reliable, good looking and it supports high horsepower. Perfect for the daily driver that doesn't run like a daily driver.



- ORB-10 inlet and outlet ports.
- For EFI applications use regulator #13101 or #13303
- For carb applications use regulator #13204 or #13304
- Fully submersible for custom, in-tank placement.
- Perfect for 'blow-through' carbureted engines up to 1200 HP.
- Speed Pump Controller (#16306) recommended for EFI street applications.

Refer to this chart for all A1000 Fuel Pumps, External and Stealth.

GAS	Naturally Aspirated	Forced Induction
Fuel Injected	1,300hp	1,000hp
Carbureted	1,500hp	1,200hp

E85	Naturally Aspirated	Forced Induction
Fuel Injected	910hp	700hp
Carbureted	1,050hp	840hp

EFI - 700lbs/hr 45psi 13.5v CARB - 700lbs/hr 8psi 13.5v

refer to flow charts on page 3 - system diagrams on page 54

E COMPATIBLE

PRO SERIES #11102

Simply the most powerful, highest flowing, in-line fuel pump available anywhere. Engineered for high horsepower racing engines this beautiful pump features our "dual chamber" design.



- ORB-12 inlet and outlet ports.
- New Black Hard Coat Anodized finish
- Includes two ORB-12 to AN-12 fittings
- EFI applications use regulator #13110 or #13134,
- Carb applications use regulator #13212 or #13202
- Perfect for "blow-through" carbureted engines up to 2,000 HP.
- Fully submersible for custom, in-tank placement.
- Speed Pump Controller (#16306) required for limited street driving.

Refer to this chart for all Pro Series Fuel Pumps, External and Stealth.

GAS	Naturally Aspirated	Forced Induction
Fuel Injected	2,200hp	1,700hp
Carbureted	2,600hp	2,000hp

E85	Naturally Aspirated	Forced Induction
Fuel Injected	1,540hp	1,190hp
Carbureted	1,820hp	1,400hp

EFI - 1200lbs/hr 45psi 13.5v CARB - 1500lbs/hr 8psi 13.5v

refer to flow charts on page 3 - system diagrams on page 54

SS SERIES

This SS Series carbureted fuel pump allows you to step up your performance by maintaining optimal line pressure and delivering high volume. The Street/Strip Pump was engineered for 200-750 HP carbureted engines making this a perfect choice for a daily driver, street rod or demanding ET-bracket race car.

ORB-08 #11213 3/8" NPT #11203

- Fuel flow exceeds 140 GPH at 13.5 volts. Supports 200-500 hp
- Perfect for use with either a Bypass Regulator (#13301) or one of our Carbureted Adjustable Regulators. (#13201, #13205)
- Pump provides 14 psi of fuel pressure - perfect for cars that leave hard.
- Pumping mechanism features our proprietary composite rotor, stainless steel vanes and precision ground, heat treated steel plates.
- Ideal for dedicated nitrous delivery.
- E85 and Alcohol compatible.
- Low current draw. (under 5 amps)

refer to flow charts on page 3 - system diagrams on page 62



E COMPATIBLE



HIGH OUTPUT

This pump is ideal for carbureted power plants that are capable of handling 7 psi, without using a separate fuel pressure regulator. The H/O Fuel Pump is designed for engines making 200-600 HP and is ideal for street cars and mild race cars alike. Similar to our SS Fuel Pump (#11203), but internally regulated to 7 psi.

ORB-08 #11219 3/8" NPT #11209

- Durable billet construction.
- Fuel flow exceeds 90 GPH at 5 psi and draws less than 5 amps.
- Internally regulated to 7 psi, eliminating the need for a separate regulator on most carburetors.
- Rated for continuous duty, the pumping mechanism features a composite rotor, stainless steel vanes, and heat-treated steel top and bottom plates for durability.

refer to flow charts on page 3 - system diagrams on page 62

E COMPATIBLE

A2000 #11202

From Stock Eliminator to Pro Mod, the Aeromotive A2000 has proven to be the most versatile "big" carbureted fuel pump on the planet.

The A2000 flows enough fuel to support the world's quickest nitrous Pro Mods on gasoline. It is the industry's only fuel pump that uses a true diaphragm controlled adjustable bypass valve, integral to the pump. This design dampens pressure spikes, which delivers smoother, more controlled flow and pressure, and ensures more consistent E.T.s and win lights.

- High torque, low RPM motor design delivers 350 GPH free flow under less current draw than any other pump in its class.
- Supports up to 2,500 hp gasoline, and up to 1,500 hp Methanol.
- Adjustable diaphragm bypass valve outperforms ineffective poppet designs, which minimizes flow loss and pressure fluctuation to the regulator and carburetor.
- ORB-10 inlet and outlet ports with ORB-08 return and 1/8" NPT gauge port.
- Proprietary seal design eliminates leakage.
- Multiple bolt patterns on the bottom of the pump body fit many mounting options.
- Ethanol, Methanol compatible.

refer to flow charts on page 3 - system diagrams on page 63



E COMPATIBLE

E COMPATIBLE

Compact, High Flow
100-micron Stainless
Steel Pre-Pump Filter



A3000

15% more flow across
the entire pressure range

6.8 gpm @ 5 psi / 13.5V
(Over 400 gph)

7.8 gpm @ 5 psi / 16V
(Over 460 gph)

Best Pressure Control of
any fuel pump in its class.

Line Pressure Adjustable
from 12-28psi
Preset at 18 psi

Modular Design
Separate & Rotate
Components for Optimal
Mounting Clearance

EXTREME CARBURETED DRAG PUMP

The new A3000 Fuel Pump is an upgrade of one of the winningest fuel pumps in drag racing: the popular A2000 Fuel Pump. The A3000 shares the same basic design and function as its predecessor, but boasts greater efficiency, less weight, and over 1 GPM more flow at pressure and never-before-seen modular features and mounting options, like a removable and indexable fuel filter and true diaphragm-controlled bypass regulator.

- Supports up to 3,000 hp on gasoline, and up to 2,000 hp on Methanol
- True diaphragm controlled bypass regulator integrated into the pump, for 14-28 psi line pressure.
- Regulator provides smoother and more controlled flow and pressure as well as dampens pressure spikes.
- The new A3000 design allows for the regulator and integrated filter to be clocked in 45° increments
- Regulator can be removed and run as a true bypass regulator.
- Regulator's bolt pattern matches up to the Aeromotive Stackable Regulators (#13217) allowing the best in pressure control and nitrous fuel system solutions.
- 15% more flow across the entire pressure range (vs. the A2000)
- New light weight design (5.1 lbs total)
- ORB-12 inlet and ORB-10 outlet
- Alcohol / Methanol / E85 compatible

PART NUMBERS

#11215 - A3000 Complete Kit
(pump, regulator, & filter)

#11216 - A3000 Carbureted Fuel Pump

#11217 - A3000 Pressure Regulator

#11218 - A3000 100-Micron Fuel Filter

#11222 - A3000 Fuel Pump & Regulator
(does not include filter)



refer to flow charts on page 3 - system diagrams on page 63

AEROMOTIVE STEALTH 340

All New STEALTH 340

The Aeromotive 340 Stealth Fuel Pump is a high-output, in-tank, electric fuel pump that fits many popular EFI applications. The Aeromotive 340 is a compact, lightweight pump that bolts into many existing hanger assemblies.

• Now fully E85 compatible

- Multiple inlet configurations
- Includes universal filter sock & pigtail
- Designed for in-tank use only
- Can be used in Carbureted or EFI applications
- Whisper quiet operation
- Turbine pump mechanism increases durability and can be used in pulse modulated applications

GAS	Naturally Aspirated	Forced Induction
Fuel Injected	850hp	700hp
Carbureted	1,000hp	850hp

E85 : New Only	Naturally Aspirated	Forced Induction
Fuel Injected	595hp	490hp
Carbureted	700hp	595hp



Also Available

IN A CELL → IN A TANK → PHANTOM FOR ANY TANK

CARB or EFI GAS or E85 Naturally Aspirated or Forced Induction



see page 13



see page 12



see page 10

refer to 340 system diagrams on pages 56-59

Stealth 340 Applications

Acura

Integra 1994-2001 #11542
NSX 1991-2000 #11541
RSX 2002-current #11542

Chrysler/Dodge/Plymouth

FWD 1984-1990 340 #11540
Stealth T/T 1991-1997 #11541
Eagle Talon 1995-1998 Turbo #11542
Eagle Talon 1990-1994 AWD #11541
Eagle Talon 1990-1994 FWD #11542
Laser 95-98 Turbo AWD&FWD #11542
Laser 1990-1994 AWD Turbo #11541
Laser 1990-1994 FWD Turbo #11542

Ford Truck

Lightning 99-00 #11542 (x2)
F150 1997-1998 #11542
F150 1999-2004 #11542

Ford

Mustang 1985-1997 (except Cobra) #11540
Mustang Cobra 1996-1997 #11542
Probe GT 1988-1992 #11541
Probe GT 1993-1997 #11542
Crown Vic/Marauder 03-04 #11542

General Motors

Grand National / Regal 1982-1987 #11569
Camaro 5.0L & 5.7L 1985-1992 #11569
Corvette 5.0L & 5.7L 1982-1996 #11569
GM Cars & Trucks 1985-1992 #11569
305 (5.0L) & 350 (5.7L) 87-97 #11569
S10, S15, Sonoma, Blazer, Envoy 82-95 #11569
Firebird 5.0L & 5.7L 1985-1992 #11569
Fiero 2.8L 1985-1986 #11569
Cyclone 1991-1992 #11569
Typhoon 1992-1993 #11569
Saturn SC,SL,SW 1997-2002 #11542

Honda

Accord 1990-1993 #11541
Accord 1994-1997 #11542
Accord 1998-2002 #11542
Civic 1988-1991 #11541
Civic 1992-2000 #11142
CRX 1989-1991 #11541
Prelude 1985-1987 #11541
Prelude 1992-1996 #11541
Prelude 1997-2001 #11542

Hyundai

Tiburon 97-01 #11542

Mazda

Miata 1994-1997 #11542
Miata 1999-2005 #11542
MX6 1988-1992 #11541
MX6 1993-1997 #11542
Protégé 90-91 #11541
Protégé 95-98 #11542
RX7 1986-1988 #11541
RX7 1989-1992 #11541
RX7 1993-1995 #11541
323 1986-1991 #11541

Mitsubishi

3000GT TT 91-97 #11541
Eclipse 95-98 Turbo #11542
Eclipse 90-94 AWD #11541
Eclipse 90-94 FWD #11542
Galant 1985-1990 #11542
*EVO 8&9 2003-2007 #11542

- Factory basket assembly MUST be replaced before converting to a 340 Stealth Pump.
- Note: If converting to E85, factory basket assembly MUST be eliminated or modified

Jeep

Wrangler 91-97 #11542
Wrangler 97-04 #11542
Cherokee 97-01 #11542
Grand Cherokee 97-98 #11542

Lexus

GS300 1993-2000 #11542
GS400 1992-2000 #11542
SC300 1992-2000 #11542
SC400 1992-2000 #11542

Nissan

D21 Pick Up 86-95 #11542
200SX 1995-1998 #11542
200SX SE-R 95-98 #11542
240SX 1989-1994 #11541
240SX 1995-1998 #11541
300ZX 1990-1996 #11542
NX1600 91-94 #11541
NX2000 91-94 #11541
Sentra 1991-1994 #11541
Sentra 1998-1999 #11542
Sentra SE 98-99 #11542
Sentra SE-R 91-94 #11541
Maxima 84-94 #11541
Maxima 1998 #11541
Altima 1993-1995 #11541
Altima 1996-2001 #11542

Subaru

Impreza WRX 98-99 #11541
Impreza 2002-2006 #11542
Impreza WRX/STi 04-07 #11542

Toyota

MR2 1991-1996 #11541
Supra 1984-1992 #11541
Supra 1994-1998 #11542
Supra Turbo 84-92 #11541
Supra Turbo 94-98 #11541
T100 1993-1998 #11542
Tacoma 1995-2001 #11542
Celica 1985-1989 #11541
Celica 90-93 Turbo AWD #11541
Celica 90-93 ST & GT #11541
Corolla 1985-1992 #11541

STEALTH 325 #11165

What sets the 325 Stealth Pump apart is its superior flow throughout a wide pressure range. Compared to other aftermarket pumps, the 325 boasts a significant increase in performance, flowing more than 325 lph at 40 psi. This pump is ideal for applications requiring more flow while retaining the factory lines and mounting provisions available in the Original Equipment (O.E.) configuration. The 325 is also perfect for use as a replacement fuel pump for applications that require more flow to support forced air power adders such as turbo and superchargers.

- Compact 65mm body for OE fitment
- Flows 325 lph @ 40 psi
- Internal check valve
- Quiet, durable and reliable turbine impeller
- Designed for in-tank use only
- Can be used in pulse modulation

Fuel Injected Engines
up to 800 HP - naturally aspirated
up to 700 HP - forced air induction



Acura RSX 2002-2006 #11165

Ford

F150/F250 1997-2004 #11165
F150 Harley-Davidson 02-03 #11165
Focus RS 15 Turbo 09-10 #11165
Mustang 1999-2004 #11165
Mustang (exc. GT500) 05-10 #11165

Holden Commodore 07-13 #11165

Honda Civic 2006-2013 #11165

Honda Civic 2001-2005 #11165

Lotus Elise 2004+ #11165

Lotus Exige 2004+ #11165

Mazda

MazdaSpeed3 2007-2012 #11165
MazdaSpeed6 2006-2007 #11165
MX5 2006-2013 #11165

Mitsubishi EVO X 08-14 #11165

Nissan R35 GTR 08-14 #11165 (x2)

Pontiac GTO 2004-2006 #11165

Scion FR-S 2013+ #11165

Subaru

Legacy GT 2005-2009 #11165
WRX/STi 2008-2012 #11165
BRZ 2013+ #11165

Toyota

Celica 2000-2005 #11165
MR2 Spyder 2000-2005 #11165
Corolla 2003-2004 #11165
Matrix 2003-2004 #11165

PHANTOM

SEMA AWARD WINNER
TESTED TO EXTREMES
INDUSTRY FAVORITE

UNIVERSAL IN TANK FUEL SYSTEMS



THE SOLUTION IS HERE

The hottest trend in hot rods and muscle cars today is late model EFI engine swaps and after market EFI systems. It's no secret why; you can make ridiculous power and do it more affordably than ever. What makes these conversions so popular is the ample supply of parts and kits from the aftermarket. Until now, the fuel system has been a costly and time consuming upgrade.

Well...Aeromotive has completely changed the game again with their newest addition to the Stealth Fuel System line-up. The Phantom Fuel System is a complete kit that gives you everything you need to install a fuel pump and baffle / basket into almost ANY fuel tank. You get an in-tank 340 Stealth Fuel Pump capable of handling serious power even at EFI pressures, a black anodized hanger assembly, and an internal baffle to control fuel slosh and keep the fuel pump submerged. The best part: this entire system is modular. It can be cut to height to fit almost any tank including your stock tank, even tanks as shallow as 6" deep.

- Install an electric fuel pump in any tank
- Sump & baffle combat fuel slosh
- Billet top hat with o-ring boss ports
- Whisper quiet operation
- Excess fuel returns to sump
- Height is adjustable for perfect fit
- Minimizes hot fuel handling issues
- Available for wide range of power



- All Kits Include:**
- Billet Installation Ring
 - Billet Top Hat with ORB-06 ports
 - Foam Baffle & Bladder Sump
 - Proprietary Sealing Gasket
 - High Flow Pre-Pump Filter
 - Billet C-Ring Mount
 - Height Adjustable Mount 6-11in*

* Horsepower ratings based on the flywheel

Phantom 200 200LPH Fuel Pump - #18689

	Naturally Aspirated	Forced Induction
EFI	600hp	450hp
Carb	750hp	600hp

Phantom Flex E COMPATIBLE 450LPH Fuel Pump - #18310

	Naturally Aspirated	Forced Induction
GAS	EFI	1,100hp
	Carb	1,300hp
E85	EFI	750hp
	Carb	900hp

Phantom 340 E COMPATIBLE 340LPH Fuel Pump - #18688

	Naturally Aspirated	Forced Induction
GAS	EFI	850hp
	Carb	1,000hp
E85	EFI	595hp
	Carb	700hp

Dual Phantom E COMPATIBLE Two 340LPH Fuel Pumps - #18309

	Naturally Aspirated	Forced Induction
GAS	EFI	1,700hp
	Carb	2,000hp
E85	EFI	1,190hp
	Carb	1,400hp

12" - 20" Extension Kits: Phantom 200 & 340 - #18788 Phantom Flex - #18710 Dual Phantom - #18709

One Hour Install visit aeromotiveinc.com/phantom for more information, and an installation video.

Step 1: Drill a 3.25in hole in the top of you fuel tank.
Step 2: Measure and Cut Hanger Bracket and Foam
(Hanger should be 1in shorter than the tank, while the foam should be taller)

Step 3: Use Installation Ring to Drill Holes & Insert Foam
Step 4: Secure Pump to Hanger, Install C-Ring, and Bolt Entire Pump Assembly Into Tank.



ONE BOX EXACTLY WHAT YOU NEED

Systems Include

- Phantom Fuel System
- Fuel Filter
- Filter Bracket
- Regulator & Gauge
- Premium Wiring Kit
- Appropriate Fittings



	Phantom 340	Phantom 200
Return Style - OEM Rail (3/8" Quick Connect)	#17166	#17167
Return Style - Dual Rail (Y-Block)	#17164	#17165
Return Style - Carbureted	#17254	#17255
Return Style - EFI Conversion / Throttle Body	#17168	#17169
Returnless - EFI Conversion / Throttle Body	#17170	#17171

STEALTH PERFORMANCE TANKS

COMPATIBLE



BUILT IN SUMP & PUMP

These are stamped steel reproduction tanks with a twist. They feature the fuel pump built right into the tank itself as well as an internal baffling system to ensure the pump is submerged in fuel even at low fuel levels and in extreme driving conditions. With these tanks you're strapping today's technology into your classic making them perfect for LS swaps and EFI conversions but still work perfectly with carbureted engines.

- Billet top hat with ORB-06 supply, vent, and return ports
- Fuel level sending unit matches OEM specs
- Includes filler neck where applicable

GAS	Naturally Aspirated	Forced Induction
Fuel Injected	850hp	700hp
Carbureted	1,000hp	850hp

refer to system diagrams on pages 56-59

- #18699 Chevy Tri Five
- #18327 62-65 Chevy II
- #18331 66-67 Chevy II
- #18330 68-69 Nova
- #18333 1970 Nova
- #18332 71-72 Nova
- #18336 73-74 Nova
- #18337 75-79 Nova
- #18334 61-64 Impala
- #18318 65-66 Impala
- #18328 70-73 Firebird
- #18335 74-78 Firebird
- #18338 79-81 Firebird
- #18657 67-68 Camaro
- #18658 1969 Camaro
- #18328 70-73 Camaro
- #18335 74-77 Camaro
- #18338 78-79 Camaro
- #18345 67-68 Camaro Notch Corners
- #18346 1969 Camaro Notch Corners

- #18325 1932 Ford
- #18326 33-34 Ford
- #18697 64-68 Mustang
- #18322 64-67 Skylark
- #18320 64-67 Cutlass
- #18319 1964 GTO
- #18324 1965 LeMans
- #18321 65-67 GTO / LeMans
- #18305 68-70 GTO / LeMans
- #18307 71-72 GTO / LeMans
- #18301 68-69 Cutlass / Skylark
- #18303 70-72 Cutlass / 70 Skylark
- #18302 1970 Monte Carlo
- #18308 71-72 Monte Carlo
- #18317 64-67 Chevelle / Malibu
- #18302 70-72 Chevelle / Malibu
- #18304 68-69 Chevelle / Malibu
- #18342 70-74 Challenger
- #18343 70-74 Barracuda
- #18344 70-76 Dart/Duster



Make It A System - Male End Fuel Filter - X1 Regulator & Gauge
The Following Kits Include: - Filter Bracket - Appropriate Fittings

Return Style - EFI OEM Rail (3/8" Quick Connect)	#17351
Return Style - EFI Dual Rail (Y-Block)	#17350
Return Style - Carbureted	#17256
Return Style - EFI Conversion / Throttle Body	#17352



APPLICATION NOT LISTED? PHANTOM IS YOUR SOLUTION

STEALTH CELLS

COMPATIBLE



These aluminum Stealth fuel cells are available in 6, 15 or 20 gallon size and fitted with any 1 of 3 popular fuel pumps. Unlike conventional fuel cells, the Stealth Cells feature an innovative baffling / basket inside and an in tank fuel pump with pre-pump fuel filter. Whether it's drifting, the weekend autocross, or a date with the drag strip, these fuel cells perform unlike anything you've seen. In fact, the Aeromotive Stealth Fuel Cells are the OE fuel system for the Ford Cobra Jet Mustang, the Chevrolet COPO Camaro, and the Mopar Drag Pak Challenger. If they can fuel these record-setting factory hot rods and meet the strict standard of the Big 3, surely they can fuel your ride.

- Choose from 3 different pumps: A1000, Eliminator or 340
- A1000 and Eliminator feature (x1) ORB-10 outlet port
- 340 Stealth features (x1) ORB-08 outlet port
- Each provide (x1) AN-08 Male Flare return port
- All include (x2) AN-08 vents with rollover safety valves
- Standard 12-bolt locking filler cap

- 15g and 20g cells feature 0-90 Ohm fuel level sending unit
- 6g dimensions: 12" w x 12" l x 10" h
- 15g dimensions: 18" w x 20" l x 10" h
- 20g dimensions: 20" w x 24" l x 10" h

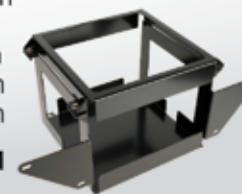

6 GAL Fuel Cell Bracket - #18701
(For 2010+ Mustangs)

340LPH		
	NA	FI
EFI	850hp	700hp
Carb	1,000hp	850hp
6G	#18659	
15G	#18664	
20G	#18665	

A1000		
	NA	FI
EFI	1,300hp	1,000hp
Carb	1,500hp	1,200hp
6G	#18666	
15G	#18660	
20G	#18661	

ELIMINATOR		
	NA	FI
EFI	1,900hp	1,400hp
Carb	2,300hp	1,700hp
6G	#18667	
15G	#18662	
20G	#18663	

NEW PRO SERIES		
	NA	FI
EFI	2,200hp	1,700hp
Carb	2,600hp	2,000hp
6G	#18645	

NA : Naturally Aspirated
FI : Forced Induction
* HP rating based to flywheel



REPLACEMENT PARTS & PUMPS

- #18006 - 6g Stealth Fuel Cell Only
- #18007 - 15g Stealth Fuel Cell Only
- #18008 - 20g Stealth Fuel Cell Only

- #18003 - A1000 Fuel Pump w/ Filter Assembly
- #18004 - Eliminator Fuel Pump w/ Filter Assembly
- #18005 - Pro Series Fuel Pump w/ Filter Assembly
- #18009 - 340 Fuel Pump w/ Filter Assembly
- #18010 - A1000 Fuel Pump Module Only
- #18011 - Eliminator Fuel Pump Module Only

THE PERFECT COMPLIMENT

Put Aeromotive in your custom tank or dual wall containment fuel cells.

- #18668 - Universal In-Tank A1000 Fuel Pump
- #18669 - Universal In-Tank Eliminator Fuel Pump

Patent No. D637,209

refer to system diagrams on page 60



STEALTH

LATE MODEL IN-TANK PUMPS



Want to make 850hp in your new Mustang? Now it's achievable, cost effective, and it's not that hard to do. The modern muscle car has evolved and Aeromotive has a fuel system solution to match. We listened and we heard the need for performance fuel systems that can keep up with the engines, the superchargers and the turbos. They had to be sleek, they had to work in conjunction with factory fuel tank, they had to be durable enough for daily driving, and...they had to be turnkey.

Aeromotive's "Late Model" Stealth Systems are designed to support big power, and they allow you to plumb a return-style system into your factory fuel tank. They are single fuel pump drop-in kits that use the factory tank, factory fuel level sending-unit, even the o-ring and retainer ring. Aeromotive offers these Stealth fuel pumps for the late C5 and C6 Corvette, 5th Gen Camaro, S197 Mustang and GT500 and the new Coyote powered 10-13 Mustangs.

- Features ORB outlet and return ports
- Incorporates factory jet siphon system and sending unit
- Includes an integrated 100 micron stainless steel pre-pump filter
- Utilizes the factory tank, o-ring, lock ring and mounting location
- Requires the use of a bypass-style regulator and return line.
- Billet Speed Pump Controller (#16306) required for EFI street applications.

A1000	Naturally Aspirated	Forced Induction
Fuel Injected	1,300hp	1,000hp
Carbureted	1,500hp	1,200hp

Eliminator	Naturally Aspirated	Forced Induction
Fuel Injected	1,900hp	1,400hp
Carbureted	2,300hp	1,700hp



MUSTANG

Aeromotive's Stealth Fuel Systems for Mustangs are a truly innovative concept in fueling today's powerful, complex muscle cars. No need for voltage boosters and expensive twin-pump systems. These Mustang stealth systems are designed to allow you to utilize your factory fuel tank, but still plumb in a return-style system and support big power. Our single fuel pump drop-in kits use the factory tank, factory fuel level sending unit, and even the o-ring / retainer ring.

All kits feature ORB-08 outlet and ORB-08 return ports

GT₀₅₋₀₉

A1000 #18676
ELIMINATOR #18677

GT500₀₇₋₁₂

A1000 #18682
ELIMINATOR #18683

GT₁₀₋₁₃

A1000 #18694
ELIMINATOR #18695

COBRA₀₃₋₀₄

A1000 #18679
ELIMINATOR #18680



CAMARO 2010-2015

The Camaro Stealth Pump is a complete drop-in single fuel pump assembly for 2010 and later Camaros. This pump is available as a single A1000 or Eliminator that drops right into your factory tank, while still incorporating the factory jet siphon system. Now with a true return-style system in your Camaro, you can support the power you're making while maintaining your factory fuel tank.

ORB-08 outlet and ORB-08 return ports

A1000 #18673 ELIMINATOR #18674



CORVETTE 2003-2013

Finally, a solution to your Corvette's fuel system needs. No more drilling your fuel tanks or risking pump failure in a 1, 2, or 3 pump set up. No more surge tanks and no more mess. Aeromotive has engineered a patent-pending, complete drop-in fuel pump available for C6 and late C5 Corvettes.

ORB-10 outlet and ORB-06 return
(fittings included)

A1000 #18670
ELIMINATOR #18671



Patent D637,210

SPUR GEAR

EXTREME CUSTOM PUMP



- Flow Ratings from **16GPM to 32GPM**
- Variety of hose attachments
- Complete line of distribution blocks and shut off valves
- Mount with 3 or 4 bolt flange or V-band
- NHRA / IHRA Certifiable



The Aeromotive Spur Gear pump is the latest and largest gear pump in the Aeromotive family. This pump features a contoured and coated body, thrust plates, & gear sets to reduce cavitation and increase longevity. From John Hale's Nostalgia Funny Car to countless Pro Mod cars, this new spur gear pump has undergone extreme testing. These relationships as well as serious research and development ensure the utmost performance and reliability under the harshest environments. Built to the strictest of standards, these pumps are sure to live up to everything you expect from Aeromotive products. Available in a complete range of flow ratings, and NHRA / IHRA certifiable options.

The Aeromotive Spur Gear line offers an assortment of inlet and outlet attachments, as well as three different sized distribution blocks to ensure proper plumbing and configuration. Mount with either a 3 or 4 bolt flange or a V-band adapter.

WE DO
RESEARCH &
DEVELOPMENT
AT 250MPH



Custom Made Pumps			
Gallons Per Minute	Shaft	Fuel	Part #
16	.375	Gas / Alcohol	#11134
16	.375	Nitro	#11934
16.75	.375	Gas / Alcohol	#11152
17	.375	Gas / Alcohol	#11148
19.5	.375	Gas / Alcohol	#11130
19.5	.375	Nitro	#11930
21.5	.375	Gas / Alcohol	#11132
21.5	.375	Nitro	#11932
25	.375	Gas / Alcohol	#11138
25	.375	Nitro	#11938
32	.375	Gas / Alcohol	#11143
32	.375	Nitro	#11943

Certifiable

NHRA Nostalgia Dragster		
20gpm	.375 shaft	#11937
NHRA Nitro Nostalgia Funny Car		
21gpm	.375 shaft	#11936
IHRA Nitro Nostalgia Funny Car		
21gpm	.375 shaft	#11935

Pre-Certified

NHRA Nostalgia Dragster		
20gpm	.375 shaft	#11941
NHRA Nitro Nostalgia Funny Car		
21gpm	.375 shaft	#11940

Inlet / Outlet



AN-20 Flare
#11732



1.25 Hose #11730
1.50 Hose #11731
1.75 Hose #11749
2.00 Hose #11750



AN-08 Port #11751
AN-10 Port #11733
AN-12 Port #11734
AN-16 Port #11752

Distrubution



AN-06 Ports #11738
AN-08 Ports #11739
AN-10 Ports #11740

Shut Off Valves (AN-8)

Left #11741
Right #11742
Left Nitro #11743
Right Nitro #11744

Mounts



3 or 4 Bolt Flange
#11736



V-Band Adapter #11735
V-Band Clamp #11737

SIX GALLONS PER MINUTE GEROTOR

E COMPATIBLE

Zero amperage draw, less weight, and more flow! The Six Series Belt Drive Fuel Pump was designed to solve fuel delivery problems in high horsepower, forced-induction EFI applications, as well as the now popular, carbureted applications on gas or methanol.

BELT DRIVE #11105 HEX DRIVE #11107

- Supports up to 3600 HP gas, 1800 HP methanol.
- Compact size facilitates easy mounting.
- Billet aluminum CNC-machined body, not "cast".
- ORB-10 inlet and outlet ports.
- For EFI applications use regulator #13113.
- Carbureted gasoline applications require regulator #13202 or #13212.
- Alcohol applications require Double Adjustable Regulator #13209 or #13214.
- Bracket and Cog Pulley sold separately.



#17140 Kit Includes:
Pump, Bracket and Pump Pulley.



refer to flow charts on page 3 - system diagrams on page 64

BB CHEVY BELT DRIVE #17241

This kit can produce anywhere from 2-200 psi with enough volume to support 2500 HP from your big block Chevy. Includes our Belt Drive Fuel Pump capable of producing high volume and supports high or low pressure whether it's fuel injected (electric or mechanical), carbureted, blown, turbocharged or nitrous assisted.

- Kit includes: Six Series Belt Drive Fuel Pump (#11105), BBC drive mandrel, pump pulley, crank pulley, cog belt, BBC mounting bracket, adjustment shims & hardware.
- Designed for lower left mounting. Must modify for right-hand mounting.
- EFI applications use Aeromotive Regulator #13113 (sold separately)
- Carbureted Gasoline : use Regulator #13202 or #13212. (sold separately)
- Carbureted Alcohol : use Regulator #13209 or #13214. (sold separately)

#17243 System with Double Adjustable Regulator (#13209)
Designed for alcohol carbureted cars



E COMPATIBLE



TWELVE GALLONS PER MINUTE GEROTOR

Designed to feed monster EFI and Carbureted engines on gasoline or alcohol. This 12gpm Belt Drive Pump is engineered to be driven by a pulley or cog drive which allows you to drive the pump from your crankshaft or camshaft. It can be used in both high or low- pressure applications.

BELT DRIVE #11115 HEX DRIVE #11117

- Flows in excess of 4,000 lbs/hr (over 11 GPM at 100 psi).
- Supports over 7,000 HP gas and 2,500 HP methanol.
- Type III hard coat anodize protects the 6061 T6 aircraft aluminum alloy housing.
- Features removable 1.25" and AN-16 inlet, and ORB-12 outlet.
- EFI applications require regulator #13113, #13132, or #13133
- Belt Drive Bracket (#11706) and Cog Pulley (#21109) see below
- Hex Drive option includes collar for standard three bolt pattern

refer to flow charts on page 3 - system diagrams on page 64

MECHANICAL PRIMING PUMP #11109

For fuel injected and carbureted applications when used with a bypass regulator. This affordable pump can support up to 500 HP naturally aspirated or 375 HP forced induction. Popular as a secondary pump, in "series" with a stock in-tank fuel pump, making a combined system capable of supporting up to 500hp forced induction.



- Universal inline pump, designed for external mounting.
- Rated for continuous duty applications.
- Flows 300 lbs. per hour @ 13.5 Volts and 45 psi.
- 5/16" hose barb inlet and outlet are standard.
- Suitable for use with Aeromotive Digital FMU #16303.
- AN-08 adapter fitting #15114 must be used in stand alone applications (sold separately)

Belt / Hex Drive Electric Priming KIT #17301

- In line EFI Fuel Pump (#11109)
- AN-08 inlet and AN-06 outlet pump adapter fittings
- ORB-10 male / ORB-06 female adapter
- Stainless Steel Braided AN hose
- All ORB fittings and AN hose ends
- Fuel Pump Wiring Kit and complete installation instructions.



34% Underdrive Pulley
GM LT-1 : #21101



32% Alternator Overdrive
Pulley (Ford & GM) : #21102



50% Alternator Underdrive Pulley
Deep V Groove (Ford & GM) : #21103



28 Tooth Cog Belt Pulley
3/8" Pitch : #21109



14 Tooth Cog Belt Pulley
3/8" Pitch, 1" ID : #21108



Timing Belt - 1/2" wide Neoprene
w/ fiberglass cord, 60 groove (22.5")
L pitch (.375") : #21110



Straight Billet Bracket for
#11105, #11115 Fuel Pumps
#11704



Billet Fuel Pump Bracket
#11105 Fuel Pump #11705
#11115 Fuel Pump #11706



Billet BBC Drive Mandrel
#21106

AEROMOTIVE DIESEL LIFT PUMP

MORE RELIABLE | MORE EFFICIENT

Aeromotive has announced that its superior fuel system technology is now available to the diesel performance enthusiast. After years of product development, Aeromotive offers a pump that will outlast and out-perform the competition. Forget everything you know about diesel lift pumps - Aeromotive has once again advanced fuel delivery technology.

The Aeromotive diesel lift pump has the flow to fuel the most aggressive street diesels. This is our first pump aimed directly at the diesel market; however, we are no strangers to it. Performance diesel enthusiasts have been using Aeromotive's in-line and t-style pumps for decades. This diesel lift pump is available as both a pump-only situation, or in vehicle specific kit form.

The Aeromotive diesel lift pump was developed to solve some key issues in the diesel lift pump market. Most notably, it solves the 1/4-tank issue, the pressure control issue, and motor shaft seal failures. Aeromotive opted for a flow-through wet motor, completely eliminating the shaft seal and ensuring that leaking seals are a thing of the past. Specific to the Duramax platform is a "fail safe" valve. In the event of electrical failure or a no-run condition, the valve will allow the injection pump to draw fuel through the diesel pump. This insures the vehicle will continue to run, getting you to your destination and eliminating expensive tow bills. With a brushless motor design, Aeromotive has increased the performance and longevity you would expect from a diesel lift pump. A single filter model simplifies the design and reduces maintenance cost. Our diesel pump includes the Caterpillar 1R-0750 2-micron filter to catch the smallest particulates. With a standard 1"-14 filter head thread, the end user can use their filter of choice.



- #11802 – Performance Street Pump (130gph flow rate)
- #11806 – Extreme Performance Pump (230gph flow rate)
- #11801 – 01-10 Chevy Duramax Complete Kit (Flows 130gph @10psi)
- #11807 – 08-10 Ford Powerstroke Complete Kit (Flows 130gph @10psi)

- #11803 – Duramax Retrofit Kit : replaces existing aftermarket lift pumps
- #11804 – Fuel line & wiring kit
- #11805 – Baffled pick up kit (5/8" feed line)



BRUSHLESS MOTOR

The latest brushless motor technology reduces current draw by 33% and offers more than double the service life of the traditional style brushed motors.



TRUE DIAPHRAGM ADJUSTABLE REGULATOR

An engineered solution designed to provide the best pressure control and flow at volume.



CAT FUEL FILTER (1R-0750)

2 Micron : Saves wear and tear on injectors and injection pumps. Standard 1"-14 filter head thread



OPTIONAL HEATER PORTS

These ports allow the customer to plumb engine coolant to the fuel pump block to keep the unit from freezing up in extreme conditions.



FUEL PRESSURE GAUGE

This allows the end user to dial in their desired fuel pressure with accuracy and reliability.



BAFFLE KIT

Solves the 1/4 tank (low fuel level) issues commonly plaguing lift pump systems.

3/4" DRAW STRAW

Reduces the amount of vacuum the pump generates by reducing the amount of air introduced to the fuel.



PRE-ASSEMBLED HOSES 5/8" PUMP FEED LINE

Push-on (industry standard) J2044 quick-connects makes installation a snap.

Reduces the amount of vacuum the pump generates by reducing the amount of air introduced to the fuel.



WEATHER PACK CONNECTORS

Simple 4 connection installation, power braided protective covering and Delphi (industry standard) Weather Pack connections for a corrosion free connection.



MORE FEATURES:

- Unique draw-through technology
- Flow-through design eliminates shaft seals failure and leaking
- Self Priming, No need to pre-fill the filter during install or filter swap
- OEM style return - no need to modify filler neck
- Complete bolt-on and plug-in installation



BETTER THAN THE SUM

Complete fuel system kits were created to provide bolt on solutions that give you trouble-free operation while saving time and money. One part number provides you with everything you need to completely install an Aeromotive fuel system on selected O.E. applications. We even carry universal kits to give you the flexibility to address fuel delivery requirements on street, drag strip, and off-road vehicles. Included are fully matched components, proper electrical connections, all the plumbing and in-depth instructions with easy-to-read text and illustrations.

All that's missing are the jack stands and hand tools.



Complete Universal Systems

These systems include everything needed for a complete Aeromotive system installation in EFI or carbureted applications. Including: filters, regulator, port fittings, stainless steel braided hose, hose-ends, wiring and installation hardware. * Requires fuel cell or sumped tank - not included.

EFI Systems

- #17125 : A1000 EFI System**
#11101 Fuel Pump, and #13101 Regulator
- #17126 : Eliminator System**
#11104 Fuel Pump and #13101 Regulator
- #17135 : A750 EFI System - Black**
#11103 Fuel Pump and #13109 Regulator
- #17136 : A750 EFI System - Red**
#11106 Fuel Pump and #13109 Regulator

Carbureted Systems

- #17201 : SS Complete System**
#11203 Fuel Pump and #13201 Regulator
- #17203 : A2000 System (single Carb)**
#11202 Fuel Pump and #13201 Regulator
- #17204 : A2000 System (dual Carb)**
#11202 Fuel Pump and #13203 Regulator
- #17242 : A1000 Carbureted System (single Carb)**
#11101 Fuel Pump and #13204 Regulator

The following systems include filters, plumbing, wiring and installation kit.

- Without Regulator
- #17122** SS Pump Kit (#11203)
- #17202** A2000 Pump Kit (#11202)
- #17245** H/O Carbureted Pump System (#11209)

- With Regulator
- #17246** SS Pump (#11203) & Regulator (#13205)
- #17247** SS Pump (#11213) & Regulator (#13201)
- #17253** Billy Glidden Signature Series Fuel System
#11202 Fuel Pump, #13212 Regulator, #14602 Dist. Log

Aeromotive Inc. is the trusted fuel system supplier for the Ford Cobra Jet Mustang, Chevrolet COPO Camaro, and Mopar Challenger Drag Pak

DRAG PAK



COPO



COBRA JET

Originally designed for the 2010 and 2012 Ford Cobra Jet Mustang, these kits give you the option to turn your S197 Mustang into a fully prepped track car or CJ clone. Choose from a variety of options that allow you to plumb just the regulator and fuel rails, or just the back-half of the car with a Stealth Fuel Cell, cell mounting bracket and post-pump filter. You can also plumb the entire system from the tank to the engine and back. These systems are complete. Included are factory fit, fuel lines, brackets and detailed instructions for installation. Nowhere can you find a more complete system designed perfectly for your application that is track tested over and over again.

Cobra Jet Engine Kit #17156

- #14141 Cobra Jet Fuel Rails
- #13128 EFI Regulator (#13101 – all black)
- #15631 Fuel Sample Valve
- All necessary fittings, lines, and hose ends for a complete installation

Cobra Jet Back Half Fuel System #17157

- #18667 Eliminator Stealth Fuel Cell + mounting bracket
- #12321 Fuel Filter and #12305 Filter Mounting Bracket
- 30' AN-08 Stainless Braided Line
- Bulkhead fittings and necessary hose-ends for installation

Cobra Jet Complete Fuel System #17158

Includes everything from #17156 and #17157 above, plus all necessary fittings, hose, hose-ends, wiring and accessories for a total fuel system installation.



GM SYSTEMS



C6 CORVETTE STEALTH SYSTEMS

The Following Kits Include:

- In-Tank Stealth Fuel Pump,
- Filter and Fuel Rails
- ORB fittings
- Wiring Kit (#16307) or Fuel Pump Speed Controller (#16306)



A1000 & Wiring Kit

- with LS1 #14106 Rails: #17172
- with LS2 #14114 Rails: #17174
- with LS3 #14115 Rails: #17176
- with LS7 #14142 Rails: #17178

A1000 & Speed Controller

- with LS1 #14106 Rails: #17173
- with LS2 #14114 Rails: #17175
- with LS3 #14115 Rails: #17177
- with LS7 #14142 Rails: #17179

Eliminator & Wiring Kit:

- with LS1 #14106 Rails: #17180
- with LS2 #14114 Rails: #17182
- with LS3 #14115 Rails: #17184
- with LS7 #14142 Rails: #17186

Eliminator & Speed Controller:

- with LS1 #14106 Rails: #17181
- with LS2 #14114 Rails: #17183
- with LS3 #14115 Rails: #17185
- with LS7 #14142 Rails: #17187

5TH GEN CAMARO STEALTH SYSTEMS

The Following Kits Include:

- In Tank Stealth Fuel Pump,
- Filter and Fuel Rails
- ORB fittings
- Wiring Kit (#16307) or Fuel Pump Speed Controller (#16306)

A1000 & Wiring Kit

with LS3 #14115 Rails: #17192

A1000 & Pump Speed Controller

with LS3 #14115 Rails: #17193

Eliminator & Wiring Kit:

with LS3 #14115 Rails: #17194

Eliminator & Speed Controller:

with LS3 #14115 Rails: #17195



FORD SYSTEMS



Fox Body Mustang Tank

- #18685 86 - 98.5 A1000 Fox Body Stealth Fuel Tank (Tank assembly)
- #18686 86 - 98.5 Eliminator Fox Body Stealth Fuel Tank (Tank assembly)
- #18690 86 - 98.5 Fox Body Stealth Tank Only (Tank only)
- #17130 86 - 95 5.0L Mustang A1000 Stealth System (Complete System)
- #17131 86 - 95 5.0L Mustang Eliminator Stealth System (Complete System)



MUSTANG STEALTH SYSTEMS

Includes In Tank Stealth Fuel Pump, Filter, Fuel Rails, ORB Fittings and Wiring Kit (#16307) or Fuel Pump Speed Controller (#16306)

* Fuel line and hose ends sold separately.

GT 2005-2009

- A1000 & Wiring Kit #17302
- A1000 & Pump Speed Controller #17303

- Eliminator & Wiring Kit #17326
- Eliminator & Speed Controller #17327

GT500 2007-2012

- A1000 & Wiring Kit #17312
- A1000 & Pump Speed Controller #17313

- Eliminator & Wiring Kit #17336
- Eliminator & Speed Controller #17337

GT 2010-2013

- A1000 & Wiring Kit #17324
- A1000 & Pump Speed Controller #17325

- Eliminator & Wiring Kit #17348
- Eliminator & Speed Controller #17349

COBRA 2003-2004

- A1000 & Wiring Kit #17312
- A1000 & Pump Speed Controller #17313

- Eliminator & Wiring Kit #17336
- Eliminator & Speed Controller #17337



EXTERNAL MUSTANG SYSTEMS

The following Aeromotive Fuel Systems come complete with everything you need to install on your Mustang. From the fuel pump, filter and regulator, to the wiring, plumbing and even the clamps to make installation as smooth and seamless as possible. When we say cradle to grave, we mean it. These systems also include the legendary Aeromotive A1000 or Eliminator Fuel Pumps.

* Requires fuel cell or sumped tank - not included.



1996-2004 SOHC 4.6L GT

- #17141 - A1000 System Only
- #17142 - Eliminator System Only

1996-1998.5 DOHC 4.6L Cobra

- #17143 - A1000 System Only
- #17144 - Eliminator System Only

1998.5-2004 DOHC 4.6L Cobra

- #17145 - A1000 System Only
- #17146 - Eliminator System Only



REGULATORS

The same standards and processes that go into developing Aeromotive pumps are used for all of our products, including our regulators. Precision engineering and integrated, proprietary, high-quality materials provide superior durability and the kind of control an inferior design can't match. Each regulator incorporates a convoluted diaphragm utilizing proprietary elastomer materials. Our material and poppet design is unique to each individual regulator. These designs maximize piston stroke and optimize flow without stressing the diaphragm. Poppet size, pressure range, and flow requirements are critical when deciding on the proper spring rate and orifice size to satisfy the specification we design to for all of our regulators. This translates to precise fuel pressure control for your specific application.

X1 SERIES REGULATORS

E COMPATIBLE



LEGENDARY AEROMOTIVE PERFORMANCE

- 1/8" npt gauge port
- 1:1 boost reference
- Carbureted or EFI
- Supports up to 2,000hp

Our First Ever Interchangeable Diaphragm, Spring & Seat

Color Coded Internals for Easy Identification

All New Light Weight Compact Design

Aeromotive's First ORB-08 Inlet/Outlet Ports



	EFI	CARB	BIG EFI
Configuration	.188" seat 35-75 psi	.313" seat 3-20 psi	.313" seat 35-75 psi
Complete Regulators	#13303	#13304	#13305
Conversion Kits Diaphragm, Spring & Seat	#13013	#13014	#13015

The Last Regulator You'll Ever Need.

Whether carbureted or EFI, naturally aspirated or forced induction, the X1 is designed to span the entire range of applications and provide dependable fuel pressure regulation. Making the change from a carburetor to EFI or EFI to carburetor? There is no longer a need to purchase a new regulator. Simply utilize one of three conversion kits (sold separately) to match the operating range required of your engine. Replace the original X1 Series regulator internals with the conversion kit of your choice (#13013, #13014, #13015) and you have a regulator with vastly different characteristics.

While versatility is one of the X1's greatest assets, it is far from the only new design feature. Utilizing larger (x3) AN-08 inlet/outlet/return ports to accommodate increased flow, Aeromotive incredibly reduced overall weight by 33% (compared to Aeromotive #13109 regulator). Even with these new design components, none of the traditional features expected of a genuine Aeromotive product have been neglected. Still integrated is the 1/8" NPT gauge port and 1:1 ratio boost reference port for easy forced induction connection. The X1 Series provides flexible performance that changes with you fuel system requirements.

PRO-SERIES

EXTREME FLOW EFI

This is the tuner's choice for high horsepower EFI applications. The Pro-Series Regulator can support up to 2,000 HP. For engines requiring high volume, high pressure fuel delivery the Pro-Series Boost Reference EFI Regulator is a perfect fit for serious power.

TWO PORT #13134 FOUR PORT #13110

- Includes two springs for 30-75 psi (installed) and 75-120 psi (provided)
- Auxiliary ports available for nitrous applications, pressure gauges etc.
- References Vacuum/Boost on a 1:1 ratio. Includes two boost line adapters: one barbed for rubber hose, the other for AN-04 braided line. (this prevents blow-off in high boost applications)
- #13110 features dedicated 1/8" NPT port.
- Includes Aeromotive's radiused, tapered flare fittings: (x3) ORB-08 and (x1) ORB-10 inlet ports, two with AN-08 flare adapters. (x1) ORB-10 return port with AN-10 flare adapter port plugs included.
- Virtually indestructible electroless nickel-plating finish on the body with type II bright dip black-anodized cap.



BELT DRIVE EFI REGULATORS

TWO PORT #13132 FOUR PORT #13133

- Designed for use with Belt or Hex Drive Fuel Pumps.
- Expanded, 5-port body with (x1) AN-10, plus (x4) AN-08 inlet/outlet ports, and (x1) AN-10 return port.
- 0.500" high flow valve/seat, able to handle 7-26 GPM
- Dual springs expand operating pressure range while maintaining a low profile and reduce weight.
- Standard spring (installed) supports 30-75 psi base
- High Pressure (included) supports 75-120 psi base
- Supports 1:1 vacuum and boost reference



SINGLE SPRING #13113

Engineered for our Belt-Drive and Hex-Drive Fuel Pumps, the Belt Drive EFI Regulator is suitable for engines making up to 4,000 HP on gasoline and is compatible with gasoline and methanol.

- Base pressure adjustable from 40-100 psi.

A1000

EFI REGULATORS



These legendary performance EFI regulators are designed for medium to high horsepower applications. Both regulators feature Aeromotive's high-flow design, superb pressure control, and legendary durability. On the street and at the track, these regulators have logged more miles, more passes, and more laps than any other performance EFI regulators in the world!

- Base pressure adjustable from 40-75 psi.
- Gasoline and alcohol compatible.
- Fuel pressure rises on a 1:1 ratio with boost.
- 1/8" NPT gauge port.

Port Sizes & Finishes

	ORB-06 RED/SILVER	#13109
	ORB-06 PLATINUM	#13159
	ORB-10 BLACK/RED	#13101
	ORB-10 PLATINUM	#13151
	ORB-10 ALL BLACK	#13128
	ORB-10 HARDCOAT	#13114



COMPACT #13129

E COMPATIBLE

Aeromotive performance in a smaller and lighter package. Capable of supporting applications up to 1000 HP, the #13129 regulator can handle high-flow EFI fuel pumps and the most aggressive street machines out there. It's perfect for those looking for a cleaner, lighter solution where performance is critical or where space is a premium.

- Base pressure is adjustable from 30-70 psi.
- (x2) ORB-06 inlet/outlet ports and (x1) ORB-06 return port.
- Dedicated, 1/8" NPT gauge port and vacuum boost port.
- Fuel pressure rises on a 1:1 ratio when referencing boost.

#13129 - Regulator only

#13130 - Regulator, (x3) ORB-06 port fittings, (x1) 0-100 psi gauge



GM LT1

E COMPATIBLE

Originally developed for the GM LT1 fuel rail, these regulators are designed to keep these cars performing at their peak potential. These rail mount EFI regulators fit a variety of factory GM vehicles. See a list of applications below:

#13106

92 - 96 Corvette
GM Ram-Jet 350 EFI Crate Engine

#13107

94 - 96 Impala
94 - 97 F Body Camaro/Firebird
GM 3.1L & 3.4L V6 engines

- Adjustable from 30-70 psi.
- Fuel pressure rises on a 1:1 ratio when referencing boost.
- 1/8" NPT gauge port.
- Stainless steel spring, custom-designed for precise fuel control.
- A true billet regulator, CAD designed and CNC-machined.
- Return adapter may be replaced with #15606 for a -06 return line.



COMPACT #13105

PLATINUM #13155

E COMPATIBLE

This is big performance in a small package. The Compact EFI Regulator is designed for applications producing up to 1,000 HP where space is at a premium. It's ideal for EFI fuel delivery systems that are limited to one regulator inlet port.

- Adjustable from 30-70 psi.
- Equipped with removable AN-06 male fittings for inlet and outlet ports, which eliminates the need to buy additional fittings and O-rings.
- Dedicated 1/8" NPT gauge port located opposite the side inlet.
- Fuel pressure rises on a 1:1 ratio when referencing boost.



HONDA

E COMPATIBLE

These billet adjustable regulators were specifically designed for Honda and Acura engines to provide fully adjustable base fuel pressure. They are direct bolt-on for engines with the factory fuel rail or aftermarket fuel rails designed with mounting provisions for the stock regulator.

#13115 (98-01 2.3L VTEC)

98 - 02 Accord 4 cyl
96 - 97 Del Sol Si
00 - 04 S2000
98 - 99 CL 2.3L

#13116 (92-97 1.6L VTEC)

86 - 89 Accord LXi/SEi
92 - 95 Civic
99 - 00 Civic Si
94 - 01 Integra

- Adjustable from 30-70 psi.
- Connects directly to the stock fuel rail and return line.
- Perfect for use with the factory fuel pump, yet flows enough for larger pumps like a Stealth 340.
- Fuel pressure rises on a 1:1 ratio when referencing boost.
- 1/8" NPT gauge port.



UNIVERSAL #13301

PLATINUM #13351

E COMPATIBLE

This universal regulator serves two purposes. It can be used for EFI or carbureted applications whether it be street or strip applications. Base pressure adjustable from 3 to 20 psi with standard spring, (installed) or from 20 to 60 psi with high pressure spring (included). It offers the full flow and rock steady fuel pressure that only a dynamic, Aeromotive bypass regulator provides.

- Capable of regulating any fuel pump between 100 and 250 GPH.
- Fuel pressure rises on a 1:1 ratio when referencing boost.
- All ports are 3/8" NPT, with one inlet and three outlets on the main body and one return port on the bottom.
- Bypass design provides the ultimate, dynamic fuel pressure control.



FORD 4.6L, 5.0L & 5.4L

E COMPATIBLE

This is an adjustable billet fuel pressure regulators designed to handle the demands of the Ford 4.6L, 5.0L and 5.4L engines. Installs easily on the stock factory fuel rail. High flow design ideal for Stealth 340 pump.

#13103 : 1986-1993 5.0L

PLATINUM #13153

#13102 : 94-98.5 4.6L & 94-95 5.0L

PLATINUM #13152

- Adjustable from 30-70 psi.
- Fuel pressure rises on a 1:1 ratio when referencing boost.
- 1/8" NPT gauge port.
- Stainless steel spring, custom-designed for precise fuel control.
- Installation kit includes O-rings and gaskets.



NEW

ULTRA LOW-PRESSURE #13222

This is one of the newest regulators in Aeromotive's line up. It's engineered with a high-flow, soft seat valve capable of supporting up to 750hp while providing a rock solid low pressure control without any creep. Simply the finest low-pressure regulator ever offered to the automotive market.

- Adjustable from 2-5 psi
- Ideal for small sidedraft-style carburetors
- (x1) ORB-6 inlet port and (x2) ORB-6 outlet
- 1/8" NPT gauge port.
- Clear anodized finish for a subtle look

GAS ONLY

SS SERIES

Carbureted Deadhead

Specifically designed for carbureted street or racing engines up to 750hp. These adjustable regulators offer higher flow, quicker response, and less pressure creep than competing two-port designs. Ideal for dedicated nitrous applications.

- Adjustable from 5-12 psi.
- Regulators re-seat after the carburetor needle shuts down, preventing pressure creep.

Port Sizes & Finishes

-  **ORB-06 #13201**
BLACK/RED #15203 Includes (x3) ORB-08 Port Fittings
#15108 Includes (x3) ORB-06 Port Fittings
-  **ORB-06 #13251**
PLATINUM
-  **ORB-06 #13211**
HARDCOAT
-  **3/8" NPT #13205**
RED/SILVER #15205 Includes (x3) 3/8" NPT / AN-08 Fittings
#15204 Includes (x3) 3/8" NPT / AN-06 Fittings
-  **3/8" NPT #13255**
PLATINUM
-  **3/8" NPT #13215**
HARDCOAT



#13205

#13201

A1000

Carbureted Bypass

The A1000 Carbureted Bypass Regulators were designed for use with our A1000 Fuel Pump or similar style EFI pumps in a carbureted application. These regulators are perfect for naturally aspirated or "blow-through" supercharged engines. They're also ideal for Phantom 200, 340, and Flex Universal Fuel Systems.

- Base fuel pressure adjustable from 3-15 psi.
- (x1) ORB-10 inlet port and (x1) ORB-08 return port.
- Fuel pressure rises on a 1:1 ratio when referencing boost.
- Bypass design provides the ultimate, dynamic fuel delivery system.
- Ideal for converting from fuel injection to carburetion with the appropriate larger return line.

#13224 : (x4) ORB-06 outlet ports and 1/8" NPT gauge port

#13204 : (x2) ORB-06 outlet ports and 1/8" NPT gauge port.

PLATINUM #13254 / HARD COAT #13207



#13224

#13204

E COMPATIBLE

A2000

Carbureted Bypass

Dynamic flow and rock steady pressure make this regulator perfect for naturally aspirated or carbureted "blow-through" applications. The A2000 Bypass Regulator provides unmatched boost reference and high-flow capacity. It's compatible with any high volume electric or mechanical fuel pump.

- Adjustable from 2-20 psi base pressure.
- Bypass design provides the ultimate, dynamic fuel delivery system. (Requires AN-10 return)
- Fuel pressure rises on a 1:1 ratio with boost.
- ORB-10 inlet and return ports.

TWO PORT #13212
FOUR PORT #13202



#13212

#13202

STACKABLE #13217

GAS ONLY

Aeromotive's Patented Stackable Carbureted Fuel Pressure Regulators are ideal for carbureted nitrous engines. These regulators allow you to "stack" them together to control multiple pressures with a single fuel pump. The new "Stackable Regulator" is a clean, lightweight solution ideal for nitrous engine combinations where unique pressures are desired.

- Adjustable from 5-12 psi.
- ORB-10 inlet and outlet flow-through ports
- (x2) ORB-06 outlet ports
- Includes (x2) O-rings, (x2) 12-point cap screws
- Serviceable in the field without having to remove from the vehicle



Pair with #11217 Regulator and inline gauge adapters for precise control.

Patent No. D628,274



*Fittings not included

DOUBLE ADJUSTABLE

Our double adjustable regulators' revolutionary design provides two independent pressure adjustments; one adjustment for idle and one for wide-open throttle. They're engineered for use with mechanical, belt, or hex drive pumps tied to engine RPM. This regulator creates the smoothest and most repeatable fuel curve from idle to wide-open throttle of any bypass system.

- Pressure range : down to 3 psi @ idle and up to 18psi @ WOT
- ORB-10 return port.
- Can be configured for single or dual-carbureted engines, and provides superior pressure control and flow when installed before the carburetor or after a fuel log.
- #13214 available with fuel log #14201 or #14202, fittings, and gauge as #17249 or #17251.

#13209 : (x1) ORB-08 inlet and (x3) ORB-08 outlet ports.

#13214 : (x1) ORB-10 and (x1) ORB-10 return.



#13209

E COMPATIBLE



#13214

PROSTOCK

CARB REGULATORS

E COMPATIBLE

Track-tested by record setting, professional racers, the Aeromotive Pro Stock Regulators were designed to be used with the Aeromotive A2000 (#11202) and A3000 (#11215) Fuel Pumps in either single or dual carburetor applications. Utilizing a new stainless steel valve, aluminum bronze seat, and an innovative opposed-spring design, the Pro Stock Regulators are engineered to be the quickest responding, most reliable, highest flowing regulators in the industry.

- Adjustable from 4-8 psi.
- ORB-12 inlet port.
(Includes ORB-12 to AN-10 inlet fitting)
- 1/8" NPT gauge port.
- Includes mounting bracket.

FOUR PORT ORB-06 #13208

TWO PORT ORB-08 #13210



A4 CARB #13203

- Soft-seat design eliminates pressure creep, making it perfect for throttle-stop cars.
- Adjustable from 5-15 psi
- Gasoline and alcohol compatible.
- Standard deadhead design, no return line required.
- (x4) ORB-06 outlet ports and 1/8" NPT gauge port.
- (x2) ORB-10 inlet ports for plumbing flexibility.



DIAPHRAGM SERVICE KITS

Complete rebuild kits for your Aeromotive fuel pressure regulator.
Note: If required, some kits will include spring as well.



Kit #	Applicable Regulators
#13001	13101, 13109, 13151, 13159, 13114
#13002	13102, 13103, 13152, 13153
#13003	13105, 13155, 13106, 13107, 13115, 13116, 13129
#13004	13110, 13224, 13134, 13304, 13305
#13005	13201, 13205, 13211, 13215, 13217, 13251, 13255
#13006	13202, 13113, 13209, 13214, 13212, 13132, 13133

Kit #	Applicable Regulators
#13007	13203
#13008	13204, 13207, 13254
#13009	13301, 13351
#13010	13208, 13210
#13701	13301, 13351 (Spring only)
#13022	13222

for appropriate X1 diaphragms, refer to page 27



THE *In-line Filter* GUIDE

*REPLACEMENT ELEMENTS

All replacement elements include (x1) filter housing o-ring



FILTERS

Finally, a place where bigger really is better. What defines an efficient filter? As little pressure drop as possible. How do you achieve a low pressure drop? Surface area. How do you get a lot of area into a compact in-line filter? Pleats. More pleats mean more surface area and in turn, better flowing filters. Aeromotive in-line filters boast the most surface area absolutely possible for the highest flowing filters.

Our fuel filters aren't just better on the inside, they are arguably the most appealing filter in the industry on the outside. They are machined out of aircraft-grade billet aluminum alloy and precision coated with your option of bright dip red or black anodizing, hardcoat, and even a nickel plated finish in our Platinum Series.

Variety, quality, unmatched performance, and finish leave all other filters in the dust. Don't trust your investment with any other filter.

FEMALE END	100 MICRON STAINLESS MESH ALL FUELS				40 MICRON STAINLESS MESH ALL FUELS		10 MICRON CELLULOSE GAS & DIESEL		10 MICRON MICRO GLASS E85 / ALCOHOL						
		12316 - RED	12366 - PLATINUM	12616 - ELEMENT	FABRIC	12303 - RED	12353 - PLATINUM	12603 - ELEMENT	12301 - RED	12321 - BLACK	12351 - PLATINUM	12306 - HARD COAT	12340 - RED	12350 - BLACK	12346 - HARD COAT
	12304 - RED	12324 - BLACK	12354 - PLATINUM	12335 - RED		12330 - BLACK	12635 - ELEMENT	12301 - RED	12321 - BLACK	12351 - PLATINUM	12306 - HARD COAT	12601 - ELEMENT	12340 - RED	12350 - BLACK	12346 - HARD COAT
	12302 - PRO SERIES	12352 - PLATINUM	12309 - HARD COAT	12602 - ELEMENT	12342 - PRO SERIES	12343 - HARD COAT	12642 - ELEMENT	12310 - PRO SERIES	12360 - PLATINUM	12311 - HARD COAT	12610 - ELEMENT	12339 - PRO SERIES	12341 - HARD COAT	12639 - ELEMENT	
	MALE END AN-06		12349 - BLACK	12348 - BLACK	12347 - BLACK	12345 - BLACK									
	AN-08		12379 - BLACK	12378 - BLACK	12377 - BLACK	12375 - BLACK									
	AN-10		12389 - BLACK	12388 - BLACK	12387 - BLACK	12385 - BLACK									
	SHUT - OFF ORB-10		12331 - BLACK	12604 - ELEMENT	7.375" long x 2" diameter	Features - Proprietary stainless steel shutoff valve design. - 10 micron stainless steel filter element. - Please see the following page for more information									
	ORB-12		12332 - BLACK	12602 - ELEMENT	8.875" long x 2.5" diameter										
	CANISTER		12318 - RED & POLISH	12319 - RED & BLACK	12618 - ELEMENT	12308 - RED & POLISH	12317 - RED & BLACK	12358 - PLATINUM	12608 - ELEMENT						
	• 3/8" NPT ports. • 6.125" x 3.75"														



STEALTH SERIES IN TANK PRE-FILTER

The new Stealth Pre-Filter is installed inside the tank. It replaces the stock fuel cell outlet bulkhead with a unique bulkhead fitting that comes with it. This bulkhead is unique because it provides support for the filter on the inside while providing the high-flow connection needed to feed the pump on the outside.

- #12612 AN-10 male flare - 100-micron stainless steel element
- #12613 AN-12 male flare - 100-micron stainless steel element

#12606 Stealth 100m Crimped Element
- screws onto existing ORB-10 cell bulkhead, or add #15646

DUAL OUTLET

New Dual Outlet Fuel Filters with secondary outlet port. Available in ORB-10 and ORB-12 port sizes. They eliminate the need for additional fittings and y-blocks, allowing you to feed separate systems from one filter.

- Features 10-micron fabric filter elements.
- Port plug for secondary port included.

- #12333 : ORB-10 ports with ORB-06 secondary port.
- #12334 : ORB-12 ports with ORB-08 secondary port.



SHUT-OFF FILTER

Ever take a fuel bath when changing your filter? We have a solution! Cleaning and replacing your filter elements used to mean draining your gas tank. The new Aeromotive Shutoff Valve Fuel Filters allow you to shutoff fuel flow and replace your filter elements with little or no fuel loss. Both feature 100-micron stainless steel elements and are recommended for use between the fuel cell or sumped tank and the fuel pump inlet.

- Proprietary stainless steel shutoff valve design.
- 100-micron stainless steel filter element.
- Type II bright dip black anodized assembly and red anodized billet aluminum shutoff valve handle.
- Perfect for pre-pump filtration.

- #12331 - ORB-10 ports (Dimensions: 7.375" long x 2" diameter)
- #12332 - ORB-12 ports (Dimensions: 8.875" long x 2.5" diameter)

MOUNTING BRACKETS

2" ORB-10 Billet Clamp #12305
PLATINUM PRESS

2.5" ORB-12 Billet Clamp #11703
PLATINUM PRESS

2" Spring Clip #12701

2.5" T-Bolt Clamp #12702



FUEL RAILS



Billet fuel rails that actually fit. The advantage of a company that understands engineering, design and manufacturing, is peace of mind. When you buy a set of rails from Aeromotive, you can be assured they will fit and deliver as promised, not leak and disappoint.

Our Rail Systems take fuel rails to another level. Adding innovative couplers allow you to install our rails on many popular domestic and import performance vehicles, while utilizing our specifically designed billet fuel pressure regulators for added tuning control.

Systems : Includes Rails, Regulator, Fuel Line, Fittings and Hose Ends
Rail Kit : Includes Fuel Rails only



FORD

4.6L MUSTANG

- Rail Kit #14103 '96 - 04 SOHC GT Kit
- Rail Kit #14104 '96 - 98 1/2 DOHC Cobra Kit
- Rail Kit #14111 '98.5 - 04 DOHC Cobra Kit
- Rail Kit #14116 '05-10 3-valve GT Kit
- System #14119 '98.5-04 SOHC GT, Returnless
- System #14125 '96-98.5 SOHC GT, Return-Style
- System #14120 '96-98.5 DOHC Cobra, Return-Style
- System #14122 '98.5 - 04 DOHC Cobra, Returnless
- System #14124 05 - 10 3-valve GT, Returnless
- System #17114 Fuel Pressure Sensor Relocation Kit (also available separately)

5.0L MUSTANG

- Rail Kit #14101 86 - 95 GT & Cobra Kit
- System #14102 GT & Cobra, Return-Style

5.4L TRUCK+SUV

- Rail Kit #14110 99-04 Lightning/Harley Kit
- Rail Kit #14117 97-05 2-Valve Truck & SUV Kit
- System #14127 99-04 Lightning/Harley, Return-Style
- System #14118 97-05 2-Valve Truck & SUV, Return-Style

5.4L GT500

- Rail Kit #14144 07-09 GT500 Kit
- System #14145 07-09 GT500, Returnless

5.0L COYOTE

- Rail Kit #14130 11-16 5.0L Coyote Mustang GT

COBRA JET

- Rail Kit #14141 10-12 5.4L Cobra Jet Mustang
*Black Anodized

GM

FUEL RAIL KITS

- #14106 97 - 04 LS1, 01 - 05 LS6 Kit
- #14113 05 - 06 Cadillac Northstar Kit
- #14114 05 - 06 LS2 Kit
- #14115 GM LS3 / L76 Kit
- #14131 96 - 07 GM Supercharged 3.8L Kit
- #14142 LS7 Corvette Kit
- #14147 Edelbrock® LS1 Intake (29085) Kit

FUEL RAIL SYSTEMS

- #14139 98 - 02 LS1 F-Body, Returnless
- #14139 04 LS1 GTO, Returnless
- #14128 99 - 04 LS1 Corvette, Returnless
- #14129 99 - 03 1/2 LS1 Corvette, Return-Style

Fuel Rail Kit: rails only Fuel Rail System: includes rails, regulator, fuel line, fittings and hose ends



SPECIALTY FUEL RAILS

- #14148 SBC Victor "E" (29785) Kit
- #14149 SBC Super Victor EFI Intake Kit (29285 & 29245)
- #14105 Mitsubishi 4G63
- #14132 Mitsubishi EVO 2003-2007
- #14163 Volkswagen / Audi 1.8L Turbo
- #14112 Acura Integra 1994-2001



MAKE YOUR OWN

- #14107 Unmachined Raw Extrusion (17.75" length, one each)



SUBARU

FUEL RAIL KITS

- #14134 **Top Feed** 2002-2014 WRX & 2007-2015 STI
- #14136 **Side Feed** 2002-2014 WRX & 2007-2015 STI

FUEL RAIL SYSTEMS

Regulator, port fittings, fuel lines and hose-ends, gauge, OEM supply and return line adapter fittings

- #14135 **Top Feed** 2002-2014 WRX & 2007-2015 STI
- #14137 **Side Feed** 2002-2014 WRX & 2007-2015 STI



MOPAR

FUEL RAIL KITS

- #14146 - Chrysler 5.7L & 6.1L HEMI
- #14158 - Mopar Gen 4 - 8.4L (V10) Viper Kit



DUAL ACTION ADJUSTABLE

FUEL LOG



- Carburetor inlets swivel + or - 20° in all directions.
- Telescoping center line is 7.700" to 13.450".
- ORB-10 inlet and outlet ports.
- (x 2) 1/8" NPT ports for gauges or pressure transducers.
- 1.056 / .806" ID bore.
- Type II bright dip black anodized finish.



- #14201 4150/4500 Holley-style float bowls
- #17248 - Includes A2000 Bypass 2-port Regulator #13212
- #17249 - Includes Double Adjustable Bypass Regulator #13214

- #14202 Demon style float bowls (9/16 x 24 Thread)
- #17250 - Includes A2000 Bypass 2-port Regulator #13212
- #17251 - Includes Double Adjustable Bypass Regulator #13214

- #14203 Holley Ultra HP-Style float bowls (3/4 x 16 Thread)

Conversion kits / inlet replacements

- #14001 - Seal Rebuild Kit for Fuel Logs
- #14002 - Inlets / Standoffs for Demon Style Inlet
- #14003 - Inlets / Standoffs for 4150/4500 Holley Style Inlet
- #14004 - Inlets / Standoffs for 3/4 x 16 Thread (Ultra HP)



ACCESSORIES

At Aeromotive, we know that developing the proper fuel system for your application is about more than just a fuel pump. It's about the complete system, with every component working in harmony to deliver optimal fuel control and ensuring your engine reaches its full potential. That's why we have developed a complete line of fuel system accessories and electronics to compliment our fuel pumps and core components. We offer everything from fuel pump speed controllers to double adjustable fuel logs. Whether you have the most standard application or the most unique, we can fuel your ride.

FUEL PRESSURE GAUGE

Featuring Built-in Equalizer Pin

While there are many advantages to the liquid filled design, there has always been an inherent issue: when underhood temperature increases, so does the oil inside the gauge. As the oil heats up and expands this causes the pressure inside the gauge to read differently. These gauges offer a pressure relief valve that equalizes pressure between the atmosphere and the gauge when activated.

0-15 PSI #15632

0-100 PSI #15633

- Includes integral pressure relief valve, for accurate readings during hot conditions
- Standard 1/8" NPT
- 1.5" Diameter
- Available for both EFI and carb applications
- Liquid-filled for increased durability

Did You Know?
Most liquid-filled gauges can give false readings due to the pressure created by heat under the hood.



FUEL PUMP SPEED CONTROLLER #16306

For any pump, on any type of vehicle, the Aeromotive Fuel Pump Speed Controller (FPSC) minimizes fuel heating and vapor-lock problems by matching the duty cycle of the fuel pump to engine RPM. At low demand, the FPSC slows the fuel pump down, reducing the chance of suction side cavitation and vapor lock. When demand increases, the FPSC returns the fuel pump to 100% duty cycle for maximum flow. It's like an automatic transmission for your fuel pump.



- Adjustable idle and full-speed RPM threshold. Uses pulse modulation to smoothly ramp speed up and down
- LED indicators confirm correct ignition signal hookup, verifies activation of the manual override circuit, and indicates when the circuit is providing full voltage to the pump.
- A solid-state transistor circuit, rated up to 40 amps, replaces the relays recommended in most fuel pump electrical circuits.
- Billet 6061-T651 aircraft aluminum housing, protected with a beautiful bright dip black anodized finish.
- Complete installation kit includes: wire, override toggle switch, installation hardware, and instructions.

Avoid any device that reduces voltage to your fuel pump. Low voltage will destroy a 12V DC motor. The Aeromotive FPSC DOES NOT reduce voltage! The FPSC emits a pulse modulation signal that is harmless to the pump's motor.

#16303 -DIGITAL PROGRAMMABLE FUEL MANAGEMENT UNIT

Now you can add fuel flow and pressure control to any return-less fuel system and maintain the proper air/fuel ratio under all WOT operating conditions. The Aeromotive FMU is a fully adjustable, scalable, electronic fuel pump controller.

- Controls auxiliary fuel pump (sold separately), mounted in-line with the stock in-tank pump.
- The unique capability of the DFMU, unlike fixed ratio mechanical FMUs, is to permit a custom pressure and flow curve for each engine application.
- The DFMU features 15 independent adjustment bands scalable across 1-30 psi of boost or any range of engine RPM. Will also scale across any 0-5 Volt input, including mass air flow signal or throttle position. LCD readout and easy programming are built in, NO laptop computer required.



Ford Digital Programmable FMU System - #17113

Complete with all the necessary components for installation on your 99 - 04 Mustang GT or Cobra. Includes: Digital Programmable FMU #16303 and Inline EFI Fuel Pump #11109

AN Y-BLOCKS



- 12 to (2)-12
#15679
- 12 to (2)-10
#15678
- 12 to (2)-8
#15677
- 10 to (2)-10
#15676
- 10 to (2)-8
#15675
- 8 to (2)-8
#15674
- 8 to (2)-6
#15673
- 6 to (2)-6
#15672
- 6 to (2)-4
#15671

ORB PORT PLUGS



ORB-10	HEX	#15617
ORB-08	Slim Line	#15618
ORB-06	HEX	#15626
ORB-06	HEX - 1/8" Gauge Port	#15697
ORB-08	HEX - 1/8" Gauge Port	#15637

ORB SWIVEL

ORB-08	ORB-10	#15638
ORB-10	ORB-10	#15640
ORB-12	ORB-12	#15680
ORB-08	ORB-06	#15681
ORB-10	ORB-12	#15682
ORB-10	ORB-10 w/ ORB-06 Port	#15639



FORD FUEL TANK BILLET RETURN ADAPTER

#18603 - ORB-08 return port



ORB Y-BLOCK

#15620 - (x1) ORB-10 and (x2) ORB-08



DIRECT PORT



ORB-06	AN-06 MALE FLARE	90°	#15689
ORB-10	AN-08 MALE FLARE	90°	#15690
ORB-10	AN-10 MALE FLARE	90°	#15691
ORB-08	AN-08 HOSE END TIGHT	90°	#15665

BULKHEAD FITTINGS

AN-06	Fuel Cell Bulkhead	#15644
AN-08	Fuel Cell Bulkhead	#15645
AN-10	Fuel Cell Bulkhead	#15646
AN-12	Fuel Cell Bulkhead	#15647
AN-06	AN-06 Male Flare	#15684
AN-08	AN-08 Male Flare	#15685
AN-10	AN-10 Male Flare	#15686
AN-12	AN-12 Male Flare	#15687

Fuel Cell



Male Flare

AN-06	Replacement Nylon Washer (2 pk)	#15044
AN-08	Replacement Nylon Washer (2 pk)	#15045
AN-10	Replacement Nylon Washer (2 pk)	#15046
AN-12	Replacement Nylon Washer (2 pk)	#15047

Banjo Fitting

ORB-08 / AN-06 Male Flare
#15636



AN HOSE ENDS

STRAIGHT AN

AN-06	Straight	#15650
AN-08	Straight	#15653
AN-10	Straight	#15656
AN-12	Straight	#15659



90° SWIVEL

AN-06	90°	#15652
AN-08	90°	#15655
AN-10	90°	#15658
AN-12	90°	#15661



45° SWIVEL

AN-06	45°	#15651
AN-08	45°	#15654
AN-10	45°	#15657
AN-12	45°	#15660



180° SWIVEL

AN-08	180°	#15663
-------	------	--------



ORB TO AN FLARE



ORB-08	AN-06	#15605
ORB-06	AN-06	#15606
ORB-08	AN-08	#15607
ORB-10	AN-10	#15608
ORB-10	AN-06	#15609
ORB-10	AN-08	#15610
ORB-12	AN-12	#15612
ORB-12	AN-10	#15613
ORB-04	AN-04	#15629
ORB-08	AN-10	#15641
ORB-10	AN-12	#15642
ORB-06	AN-08	#15649

AN FLARE UNION

AN-06	AN-06	#15602
AN-08	AN-08	#15603
AN-10	AN-10	#15604
AN-12	AN-12	#15611
AN-08	AN-06	#15614



NPT / AN FLARE

3/8" NPT	AN-06	#15615
3/8" NPT	AN-08	#15616
1/16" NPT	AN-04	#15619
1/16" NPT	5/32"	#15630



FEMALE COUPLER

AN-08	AN-08	#15692
-------	-------	--------



HOSE BARB

ORB-06	7mm	#15627
ORB-04	5/16"	#15628
AN-06	5/16"	#15635



ONE WAY CHECK VALVE

ORB-10 #15107 ORB-06 #15106

Our high flow one-way check valves are designed to prevent back-flow with minimal pressure drop. Ideal to prevent drain back after the fuel pump is turned off, or when dual pumps are used and both pumps may not run simultaneously.

- CNC-machined billet aluminum and Type II bright dip black anodized finish.
- AN O-ring male inlet/female outlet connections allow easy installation into fuel pump or filter outlet port without adding additional lines, hose-ends or fittings.
- Suitable for use with gasoline fuels only.



STAINLESS STEEL RUBBER BRAIDED

FUEL LINE



SIZE	LENGTH	PART #
AN-06	4'	#15701
AN-06	8'	#15702
AN-06	12'	#15703
AN-08	4'	#15704
AN-08	8'	#15705
AN-08	12'	#15706
AN-08	16'	#15711
AN-10	4'	#15707
AN-10	8'	#15708
AN-10	12'	#15709
AN-10	20'	#15710

SUMPED BOX #18650

Take advantage of Aeromotive's leading edge engineering and design. You can keep all the benefits of our Mustang sumped fuel tank in virtually any automotive application by installing the #18650 sump box. Perfect for EFI crate engine installations and early muscle cars and trucks.

- Can be welded into virtually any fuel tank
- Sump design features a large reservoir volume, floor to ceiling baffling and proprietary return ramp to ensure a constant head of calm fuel is always available at the pump's inlet, right down to "E."
- (x2) ORB-10 outlet ports and (x1) ORB-10 return port



Premium Fuel Pump WIRING KIT

#16307
30 AMP



Value Fuel Pump WIRING KIT
#16301- 30 AMP

FUEL SAMPLE VALVE #15631

Aeromotive's Billet Fuel Sample Valve is designed to simplify installation and make fuel checks a snap! Packed with common sense features, it's simply the best sample valve on the market.

- Installs into any 1/8" NPT gauge port.
- Provides a duplicate 1/8" NPT port on the valve for installation of fuel pressure gauge or pressure sensor transducer.
- Sample port is equipped with a stainless steel barb fitting for extension hose and rotates 360° for ease of installation and sampling.
- The "dual action", spring-loaded safety valve keeps the valve sealed when unlocked and rotates into a locked position for racing.



#17119 - 3/8" Quick Connect Sample Valve Kit,
Fits most Ford Modular and GM LS Series Engines

ORB-AN FLARE WITH IN LINE GAUGE ADAPTER

ORB-06	AN-06 MALE FLARE	1/8" NPT Port	#15694
ORB-08	AN-08 MALE FLARE	1/8" NPT Port	#15695
ORB-10	AN-10 MALE FLARE	1/8" NPT Port	#15696



VACUUM PUMP REGULATOR #33101

Aeromotive's new Vacuum Pump Regulator allows you to control and adjust crankcase vacuum easily and effectively without the use of shims. Simply loosen the lock nut and turn to adjust.

- Attaches directly to the Aeromotive Vacuum Pump. (Note: Use port fitting #15612)
- Equipped with (2) ORB-12 Inlet and Outlet Ports.
- Features a 1/8" gauge port.
- Made from CNC-Machined Billet Aluminum

Patent No. D622,288



REPLACEMENT ORB RINGS

ORB-06	Fuel Resistant Nitrile - 10 Pack	#15621
ORB-08	Fuel Resistant Nitrile - 10 Pack	#15622
ORB-10	Fuel Resistant Nitrile - 10 Pack	#15623
ORB-12	Fuel Resistant Nitrile - 10 Pack	#15624

REPLACEMENT FILTER O RINGS

2" Diameter Filter Housings	#12001
2.5" Diameter Filter Housings	#12002
1.25" Diameter Filter Housings	#12003
Canister Style Filter Housings	#12008
A3000 Pre-Filter	#12018



Ford Male Spring Lock Adapter

Ford 1/2" Male Spring Lock / AN-06 Feed Line Adapter : #15124

Ford 3/8" Male Spring Lock / AN-06 Feed Line Adapter : #15123

Ford 1/2" Male Spring Lock / AN-08 Feed Line Adapter : #15125



1/2" Quick Connect / ORB-10 #15128
3/8" Quick Connect / ORB-08 #15118
5/16" Quick Connect / ORB-06 #15117

4 Port Fuel Distribution Log

#14601 - (x2) ORB-08 and (x2) ORB-06



10 Port Fuel Distribution Log

#14602 - (x2) ORB-10 and (x8) ORB-06



REPLACEMENT STEALTH FILTER SOCKS



Phantom 200 & 340, includes gasket	#12688
Phantom Dual #18309, includes gasket	#12609
Phantom Flex #18310, includes gasket	#12611
340 Stealth Pump - #11540	#12640
340 Stealth Pump - #11541 and #11542,	#12641
340 Stealth Pump - #11569	#12669



AN-08 Inlet Male Flare Adapter for Inline EFI Pump (#11109) : #15114



3/8" Quick Connect with AN-08 fuel access port and 1/8" NPT gauge port : #15121



5/16" Quick Connect with AN-06 Fuel Access port and 1/8" NPT gauge port : #15120



Demon Carb AN-06 to 9/16" x 24 Thread Float Bowl Fitting : #15207



Demon Carb AN-08 to 9/16" x 24 Thread Float Bowl Fitting : #15208



Holley AN-06 to 7/8" x 20 Thread Float Bowl Fitting : #15201



1/16" NPT to AN-04 Vacuum Boost fitting for port on regulators : #15619



1/16" NPT to 5/32" Hose Barb for vacuum/boost port on regulators : #15630



1/16" NPT Breather Vent for Vacuum/Boost port on Regulators : #15662



3/8" Female Spring-Lock / AN-06 Male (Ford Return Line) : #15101



3/8" Male Quick Connect / AN-10 Male (GM LT-1 filter inlet) : #15104



5/16" Male Quick Connect / AN-06 Male (Ford filter inlet / outlet) : #15103



Ford 4.6L Sensor Adapter Log (2) ORB-08 Ports
#15112 - 1999-2004 Adapter
#15115 - 2005-2006 Adapter



5/8" Female to AN-10 Male (GM LT-1 filter outlet) : #15105



Fuel Pump Vibration Dampener Mounting Kit #11601



1/2" Female Spring-Lock / (2) AN-08 Male "T" (86-06 Ford Supply Line) : #15102



3/8" Male Quick Connect / (2) ORB-08 Male Flare "T" (GM pressure line) : #15116



2x Male AN-08 x ORB-06 Port Tee with 1/8" NPT gauge port : #15119

MARINE

HARD COAT ANODIZE



More than a label : these products have passed intense pressure, explosive, and electrical testing.

The Aeromotive Marine line is serious fuel delivery for serious performance watercraft. Similar to our street and performance products, the Aeromotive Marine line of products are each certified to ISO 8846, SAE J1171, and United States Coast Guard Requirements for Ignition Protection & Fire Resistance. They are hardcoat anodized for superior corrosion resistance and each product carries a 2-year limited warranty. All Aeromotive products are designed, built, and tested to the strictest tolerances in the industry, and the Aeromotive Marine line of products are no exception. This line comes with quality, performance, durability, and a company that stands behind every product that carries the "Aeromotive" name.



Coast Guard Certified



Hard Coat Black Anodize



Same Legendary Performance

PLATINUM

The Aeromotive Platinum Series features a mirror nickel finish for a show quality line of fuel system components prepared for the discriminating street rod and show car builder.



Fuel Pumps

A1000	#11108
ELIMINATOR	#11110
SS SERIES	#11211
HO SERIES	#11212

Fuel Filters

ORB-10 : 100m stainless	#12307
ORB-12 : 100m stainless	#12309
ORB-12 : 40m stainless	#12343
ORB-10 : 10m cellulose	#12306
ORB-12 : 10m cellulose	#12311
ORB-12 : 10m microglass	#12341



Regulators

A1000 - Carb Bypass	#13207
Same as #13204	
A1000 - EFI Bypass	#13114
Same as #13101 - ORB-10 ports	
SS Series	#13211
Same as #13201 - ORB-06 Ports	
SS Series	#13215
Same as #13205 - 3/8" NPT Ports	



Fuel Pumps	
A1000 Fuel Pump	#11151
A750 EFI Fuel Pump	#11156
SS Street / Strip Fuel Pump	#11253
H/O Electric Fuel Pump	#11259

Filters

ORB-10 10-micron	#12351
ORB-10 100-micron	#12354
ORB-12 10-micron	#12360
ORB-12 100-micron	#12352
3/8" NPT 40-micron	#12353
3/8" NPT 100-micron	#12366
Canister 10-micron	#12358

Regulators

A1000 Injected Bypass	#13151
Ford 5.0L and 4.6L Rail Mount	#13152
Ford 5.0L and 4.6L Rail Mount	#13153
Compact EFI	#13155
A1000-6 Injected Bypass	#13159
SS AN-06	#13251
A1000 Carb Bypass	#13254
SS 3/8" NPT	#13255
Universal Bypass	#13351

POWER PLANNER

GUIDE TO SUCCESSFUL FUEL SYSTEMS



IMPORTANT!

The following are the basic solutions to the most common systems.

For more specific diagrams, or variables of the following, visit AeromotiveInc.com/diagrams or call 913-647-7300

QUICK KEY



340 STEALTH DIAGRAMS

Diagrams Labeled "340 Stealth" are applicable for ALL 340 Stealth Products

Phantom Series 200 & 340 : see page 10
Stealth Performance Tanks : see page 12
340 Stealth Fuel Cells : see page 13

Stealth 340 Pumps : see page 8
(Drop in, upgrade pump. Fittings in top hat won't be applicable)



Refer To Filter Guide on page 37 for all available options and finishes



KEY 100M = 100 MICRON ELEMENT 10M = 10 MICRON ELEMENT 10M = E85 COMPATIBLE ELEMENT

Remember these...



Wiring Kit #16307



Pressure Gauge
0-15 psi #15632
0-100 psi #15633



Fuel Pump Speed Controller #16306



Filter Brackets
page 38



Fuel Line & Hose Ends
page 45

A750 Dual Fuel Rail Fuel Injected

*flywheel	Naturally Aspirated	Forced Induction
Fuel Injected	800hp	600hp

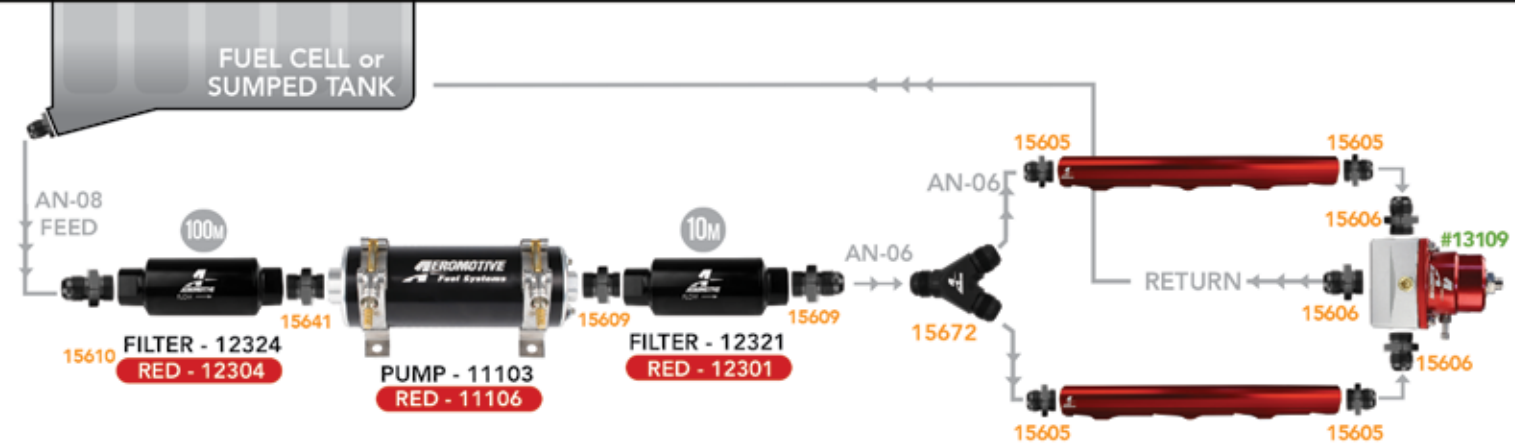

* Pre Pump : Separate the pump from filter with a #15610 fitting, #15607 fitting, and -08 line.
** Post Pump : Separate the pump from filter with a #15606 fitting, #15609 fitting, and -08 line.

A750 Single Fuel Rail Fuel Injected

*flywheel	Naturally Aspirated	Forced Induction
Fuel Injected	800hp	600hp



* Pre Pump : Separate the pump from filter with a #15610 fitting, #15607 fitting, and -08 line.
** Post Pump : Separate the pump from filter with a #15606 fitting, #15609 fitting, and -08 line.

A750 Single Feed Carbureted

*flywheel	Naturally Aspirated	Forced Induction
Carbureted	1,000hp	800hp

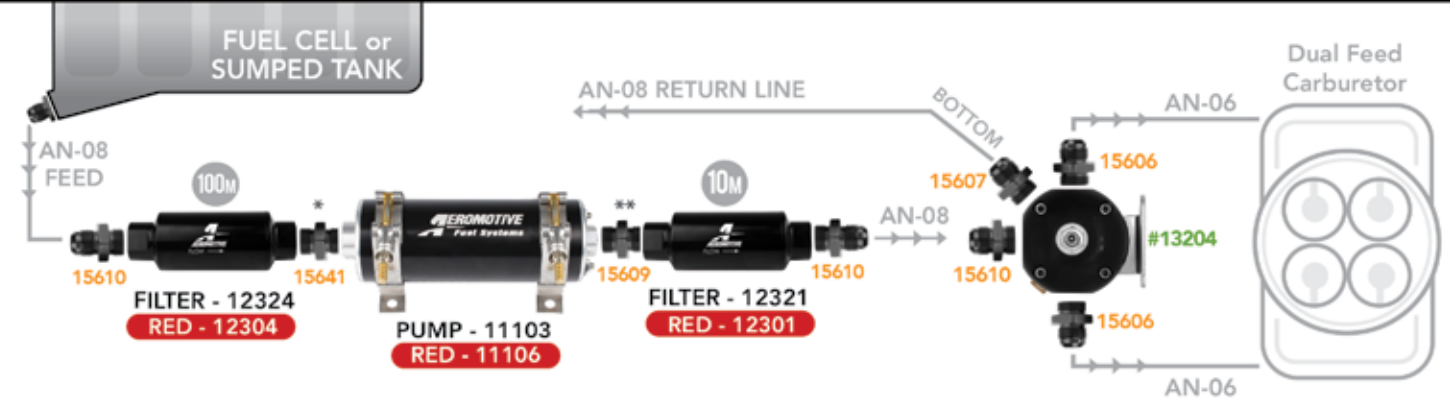

* Pre Pump : Separate the pump from filter with a #15610 fitting, #15607 fitting, and -08 line.
** Post Pump : Separate the pump from filter with a #15606 fitting, #15609 fitting, and -08 line.

A1000 Dual Fuel Rail Fuel Injected

*flywheel	Naturally Aspirated	Forced Induction
GAS	1,300hp	1,000hp
E85	910hp	700hp



* Pre Pump : Separate the pump from filter with two #15608 fittings, and -10 line.
 ** Post Pump : Separate the pump from filter with two #15610 fittings, and -08 line.

A1000 Dual Feed Carbureted

*flywheel	Naturally Aspirated	Forced Induction
GAS	1,500hp	1,200hp
E85	1050hp	840hp



* Pre Pump : Separate the pump from filter with two #15608 fittings, and -10 line.
 ** Post Pump : Separate the pump from filter with two #15608 fittings, and -10 line.

ELIMINATOR Dual Fuel Rail Fuel Injected

*flywheel	Naturally Aspirated	Forced Induction
GAS	1,900hp	1,400hp
E85	1,330hp	980hp



* Pre Pump : Separate the pump from filter with two #15612 fittings, and -12 line.
 ** Post Pump : Separate the pump from filter with a #15608 fitting, #15613 fitting and -10 line.

ELIMINATOR Fuel Log Carbureted

*flywheel	Naturally Aspirated	Forced Induction
GAS	2,300hp	1,700hp
E85	1,610hp	1,190hp



* Pre Pump : Separate the pump from filter with two #15612 fittings, and -12 line.
 ** Post Pump : Separate the pump from filter with a #15608 fitting, #15613 fitting and -10 line.

PRO SERIES Dual Fuel Rail Fuel Injected

*flywheel	Naturally Aspirated	Forced Induction
GAS	2,200hp	1,700hp
E85	1,540hp	1,190hp



* Pre Pump : Separate the pump from filter with two #15612 fittings, and -12 line.
 ** Post Pump : Separate the pump from filter with two #15613 fittings and -10 line.

PRO SERIES Dual Feed Dual Carbureted

*flywheel	Naturally Aspirated	Forced Induction
GAS	2,600hp	2,000hp
E85	1,820hp	1,400hp



* Pre Pump : Separate the pump from filter with two #15612 fittings, and -12 line.
 ** Post Pump : Separate the pump from filter with two #15613 fittings and -10 line.

STEALTH 340 Dual Fuel Rail Fuel Injected

*flywheel	Naturally Aspirated	Forced Induction
GAS E85	850hp 595hp	700hp 490hp

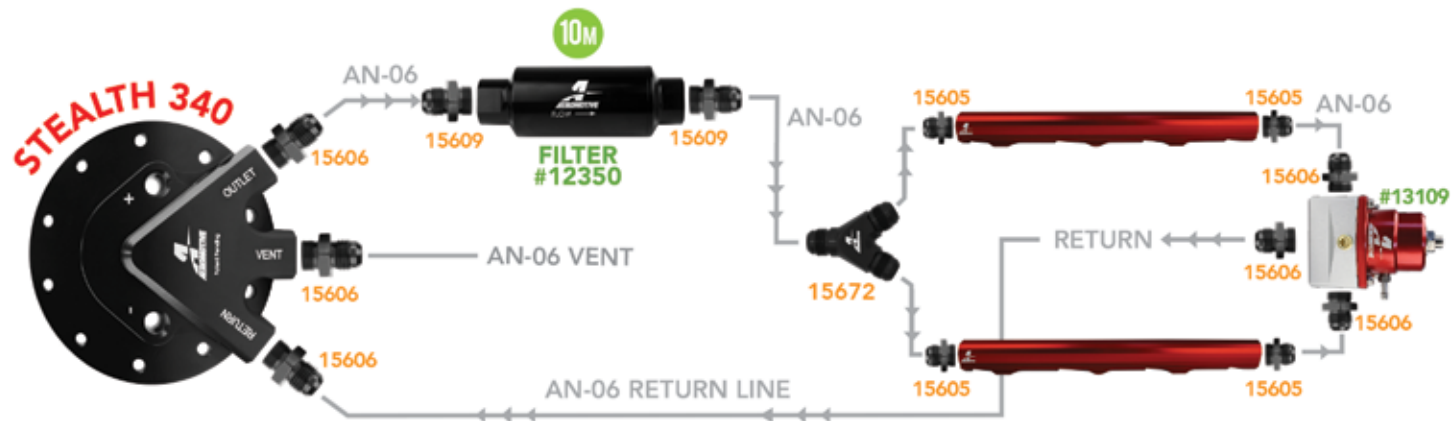

STEALTH 340 Throttle Body EFI Conversion

*flywheel	Naturally Aspirated	Forced Induction
GAS	850hp	700hp



STEALTH 340 OEM Fuel Rail Fuel Injected

*flywheel	Naturally Aspirated	Forced Induction
GAS	850hp	700hp

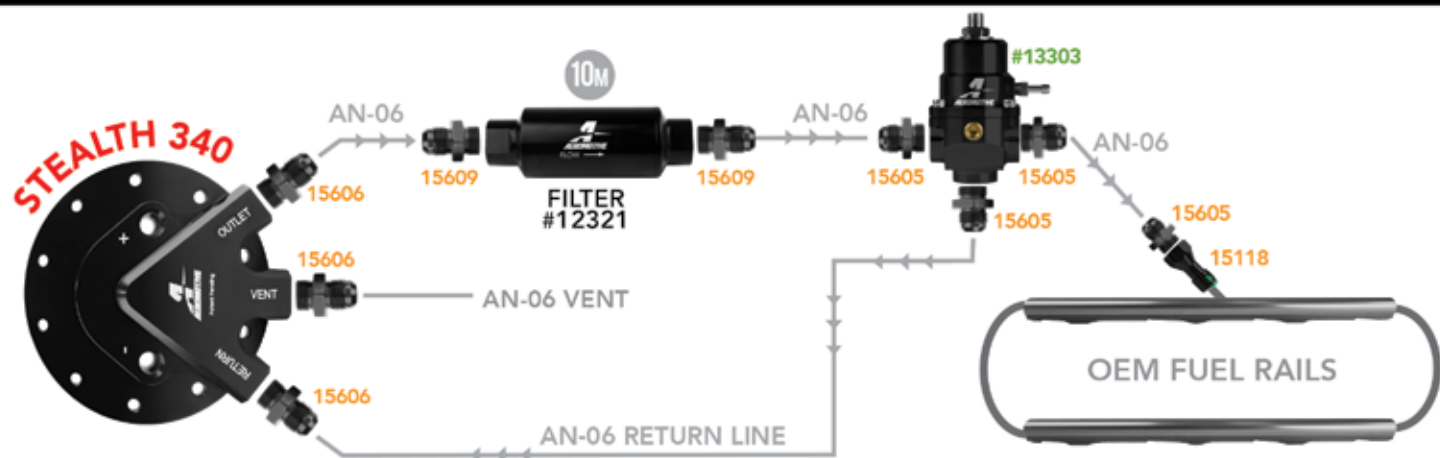

STEALTH 340 Dual Feed Carb - Return

*flywheel	Naturally Aspirated	Forced Induction
GAS	1,000hp	850hp

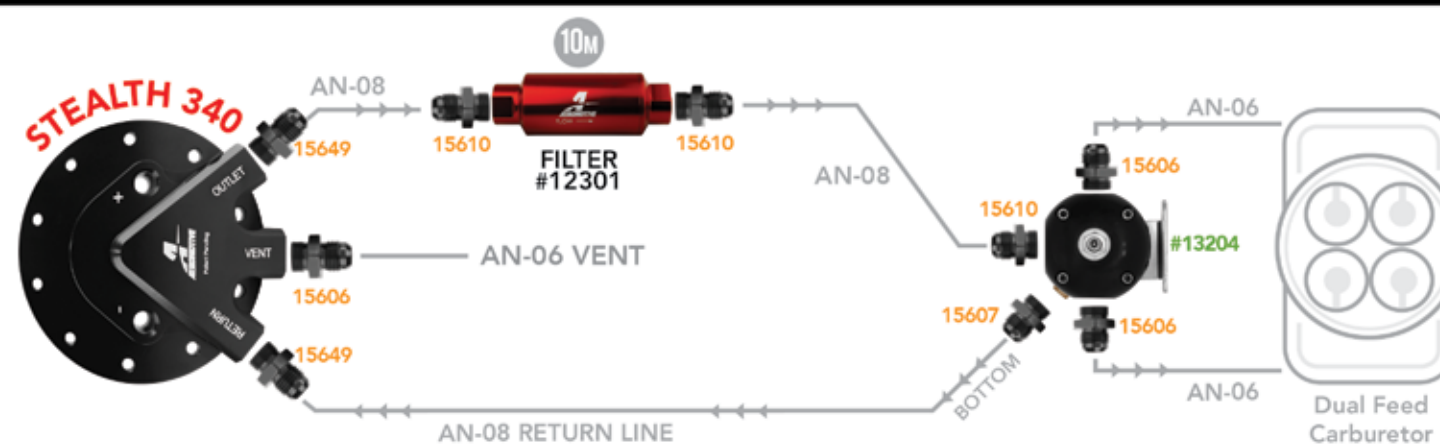

STEALTH 340 Single Fuel Rail Fuel Injected

*flywheel	Naturally Aspirated	Forced Induction
GAS	850hp	700hp

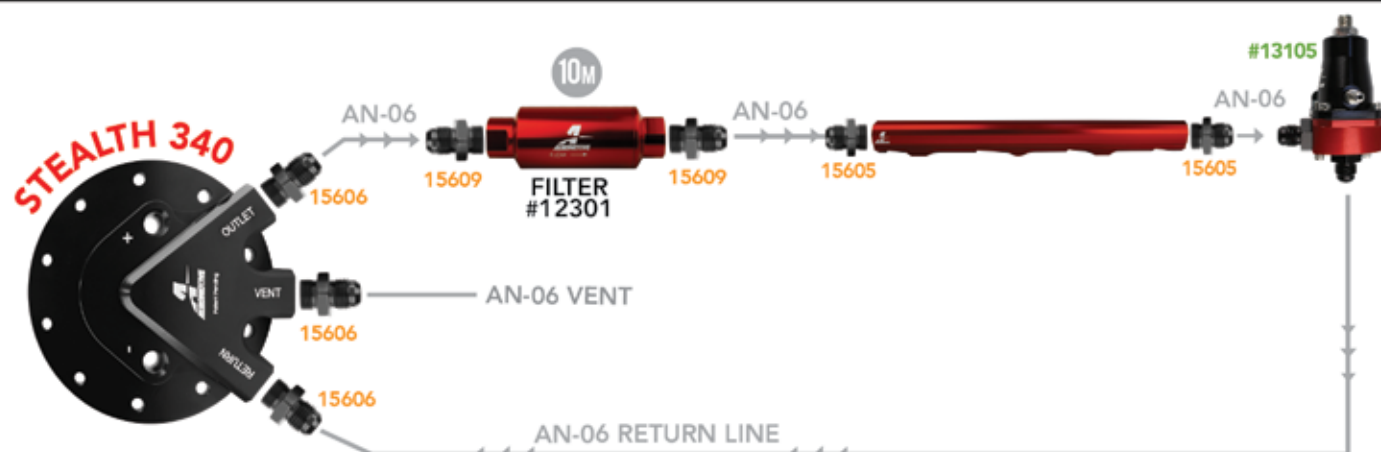

STEALTH 340 Two Stage Nitrous Carb - Return

*flywheel	Naturally Aspirated	Forced Induction
GAS	1,000hp	850hp

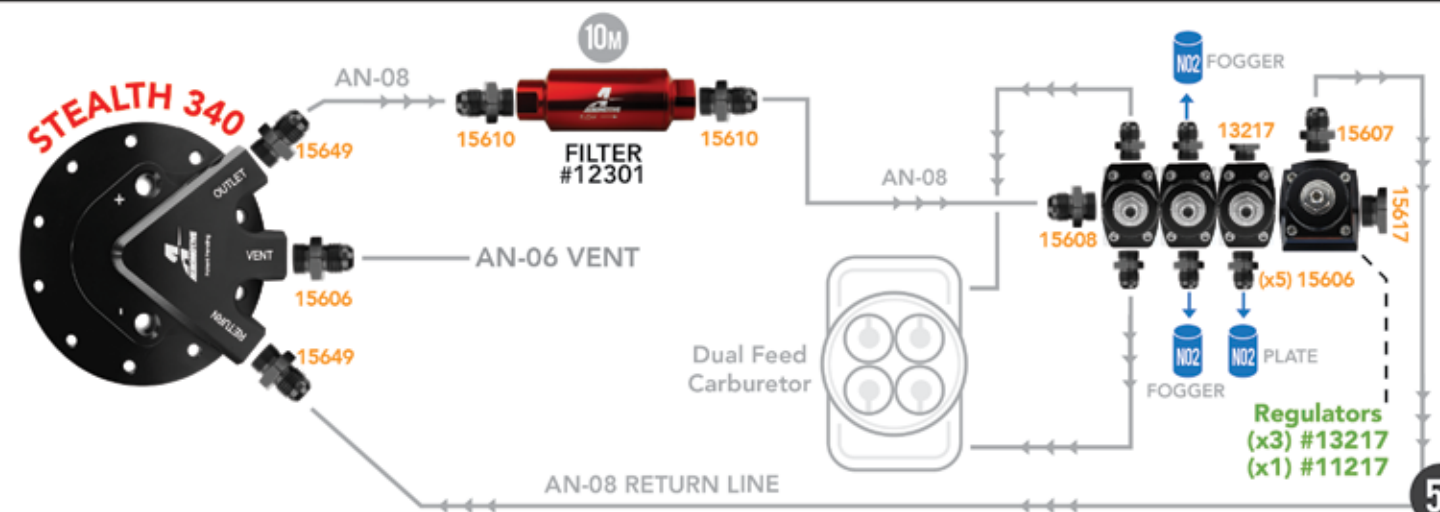

PHANTOM FLEX Dual Fuel Rail Fuel Injected

*flywheel	Naturally Aspirated	Forced Induction
GAS	1,100hp	800hp
E85	750hp	550hp

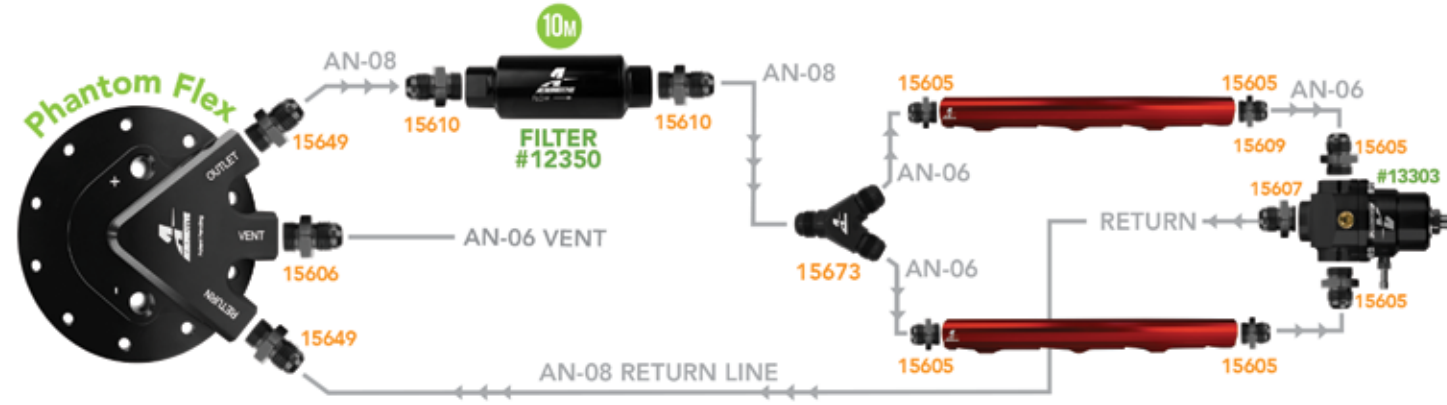

PHANTOM FLEX Fuel Log Carb - Return

*flywheel	Naturally Aspirated	Forced Induction
GAS	1,300hp	950hp
E85	900hp	700hp

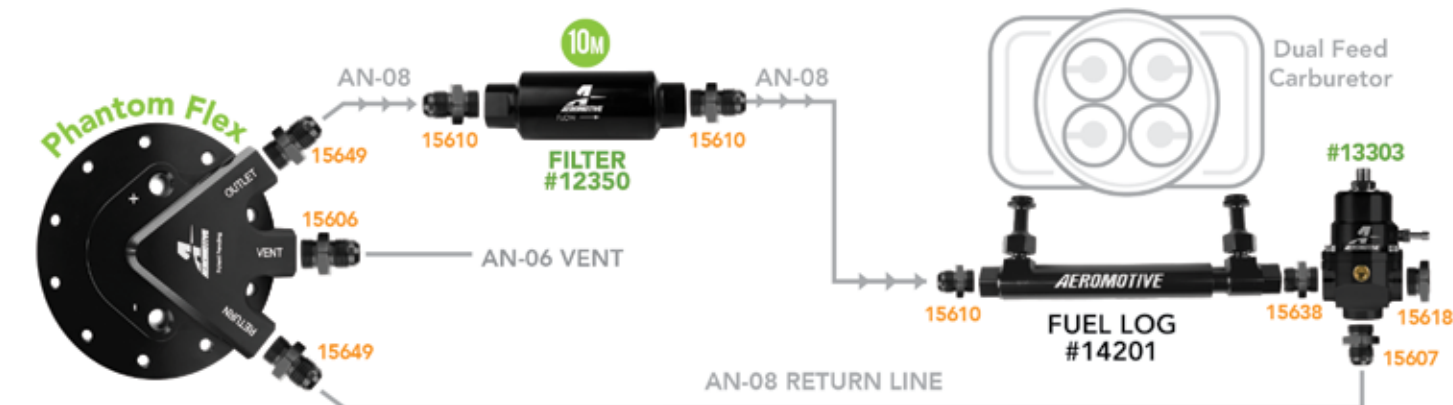

DUAL PHANTOM Redundant EFI - Dual Rail

*flywheel	Naturally Aspirated	Forced Induction
GAS	850hp	700hp

The following diagram is for ONE pump to run at a time.

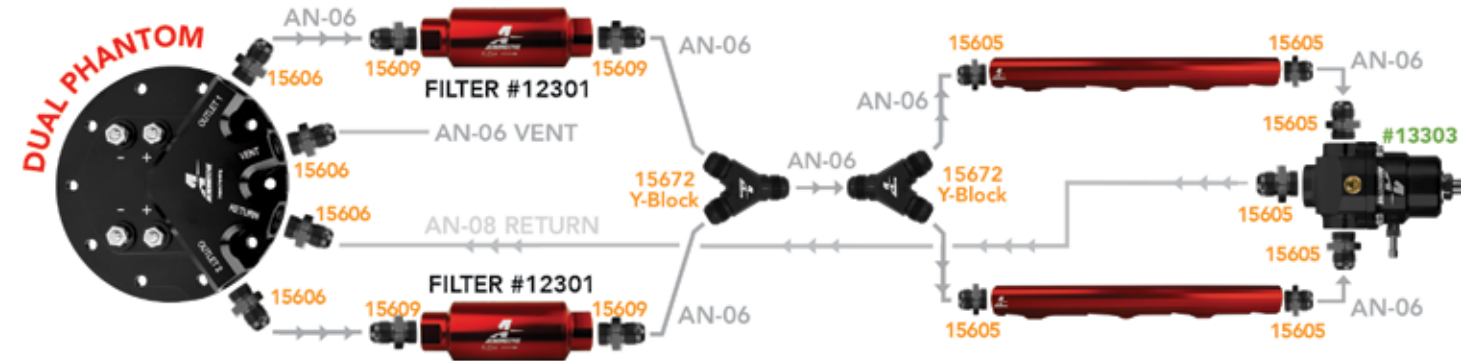

DUAL PHANTOM Staged Carb

*flywheel	Naturally Aspirated	Forced Induction
GAS	1,000hp	850hp

The following diagram is for BOTH pumps to run at once

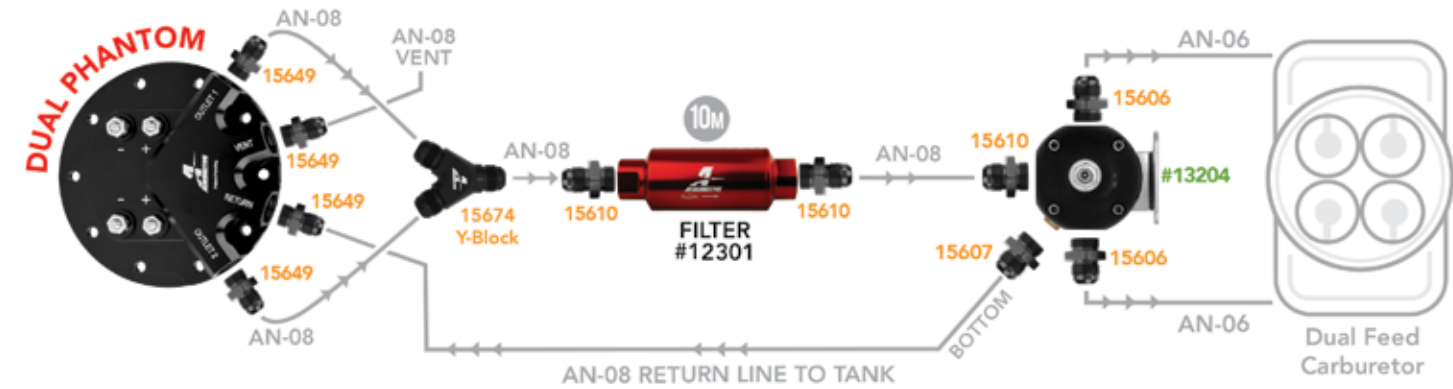

DUAL PHANTOM Staged EFI - Dual Rail

*flywheel	Naturally Aspirated	Forced Induction
GAS	1,700hp	1,400hp
E85	1,190hp	980hp

The following diagram is for BOTH pumps to run at once

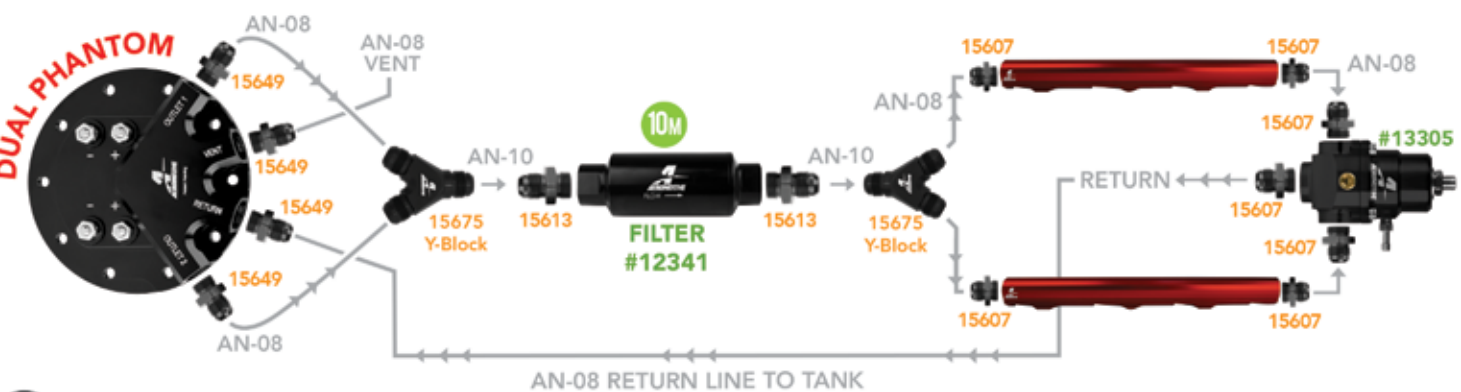

DUAL PHANTOM Staged Carb - Dual Rail

*flywheel	Naturally Aspirated	Forced Induction
GAS	2,000hp	1,700hp
E85	1,400hp	1,190hp

The following diagram is for BOTH pumps to run at once

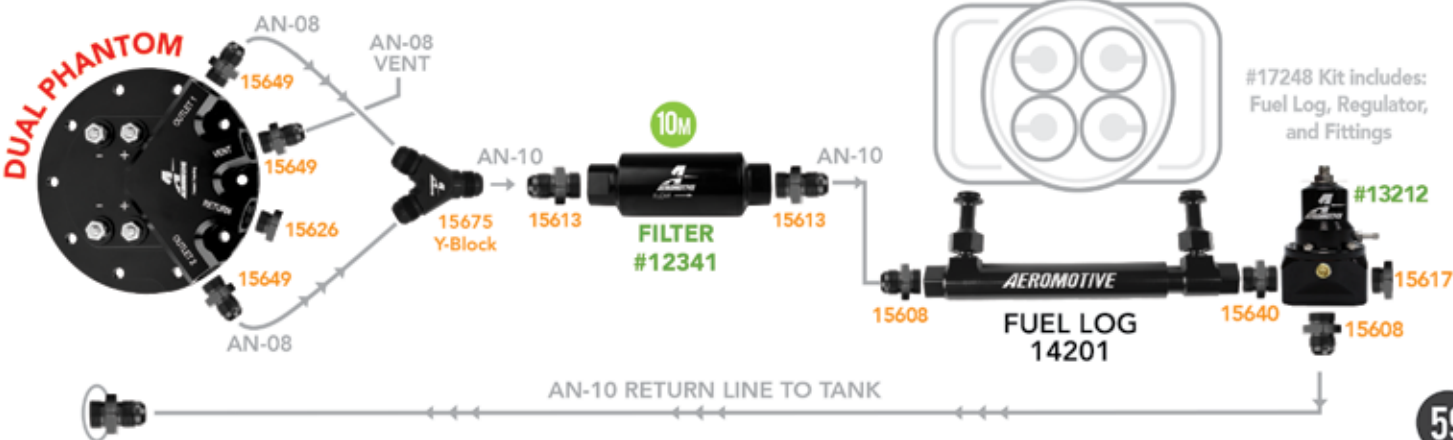

A1000 Dual Fuel Rail Fuel Injected

*flywheel	Naturally Aspirated	Forced Induction
GAS	1,300hp	1,000hp

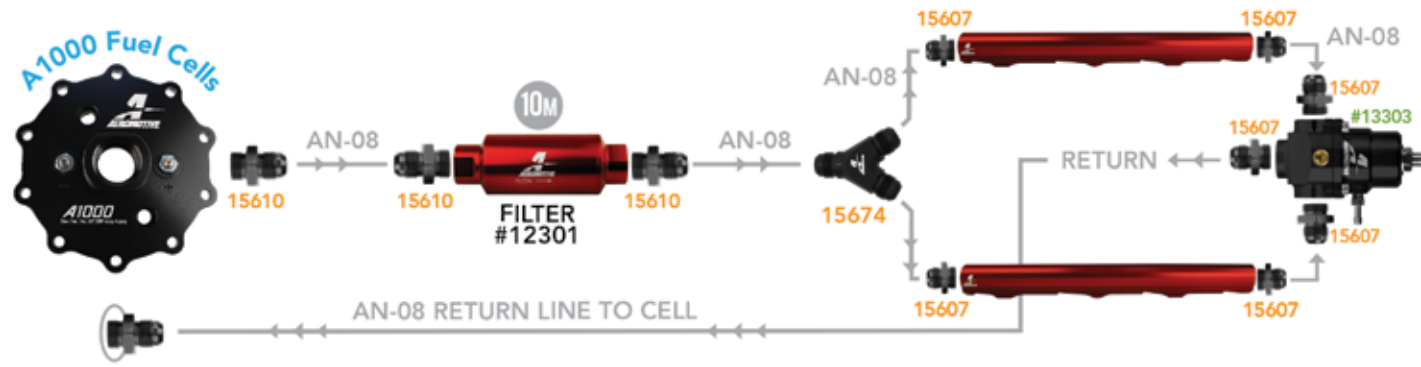

A1000 Dual Feed Carbureted

*flywheel	Naturally Aspirated	Forced Induction
GAS	1,500hp	1,200hp

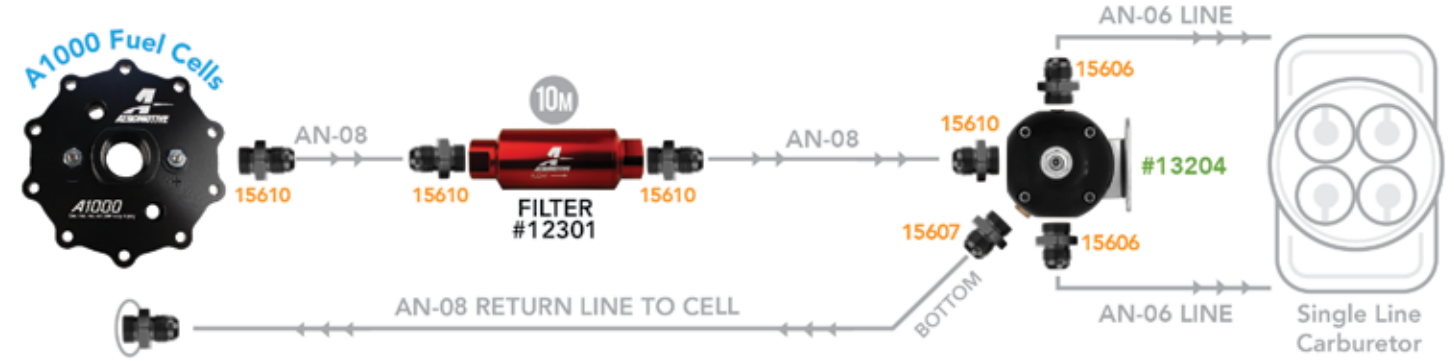

ELIMINATOR Dual Fuel Rail Fuel Injected

*flywheel	Naturally Aspirated	Forced Induction
GAS	1,900hp	1,400hp
E85	1,330hp	980hp

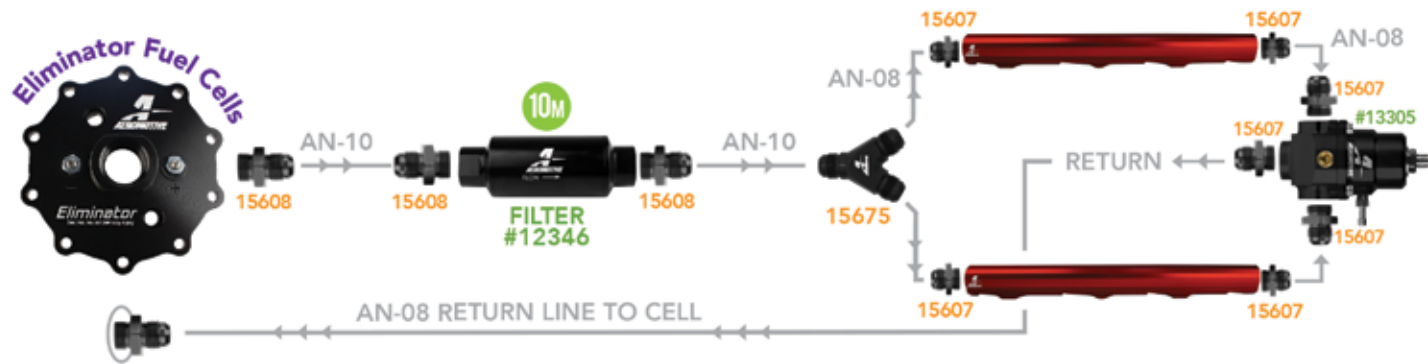

ELIMINATOR Dual Feed Carbureted

*flywheel	Naturally Aspirated	Forced Induction
GAS	2,300hp	1,700hp
E85	1,610hp	1,190hp

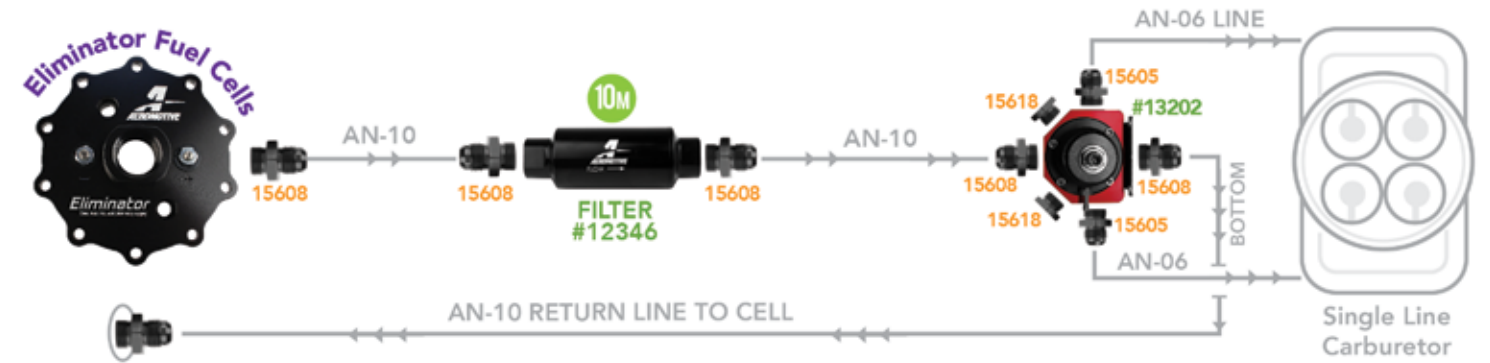

ELIMINATOR Fuel Log Carbureted

*flywheel	Naturally Aspirated	Forced Induction
GAS	2,300hp	1,700hp
E85	1,610hp	1,190hp

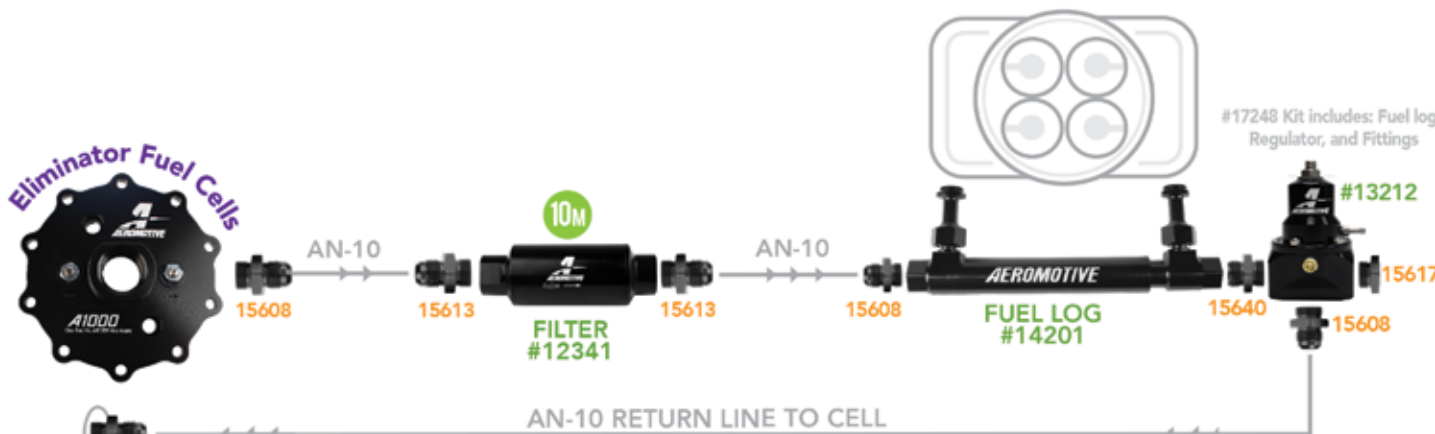

ELIMINATOR Stackable Regulators Dual Feed Carb

*flywheel	Naturally Aspirated	Nitrous
GAS	2,300hp	1,700hp
E85	1,610hp	1,190hp

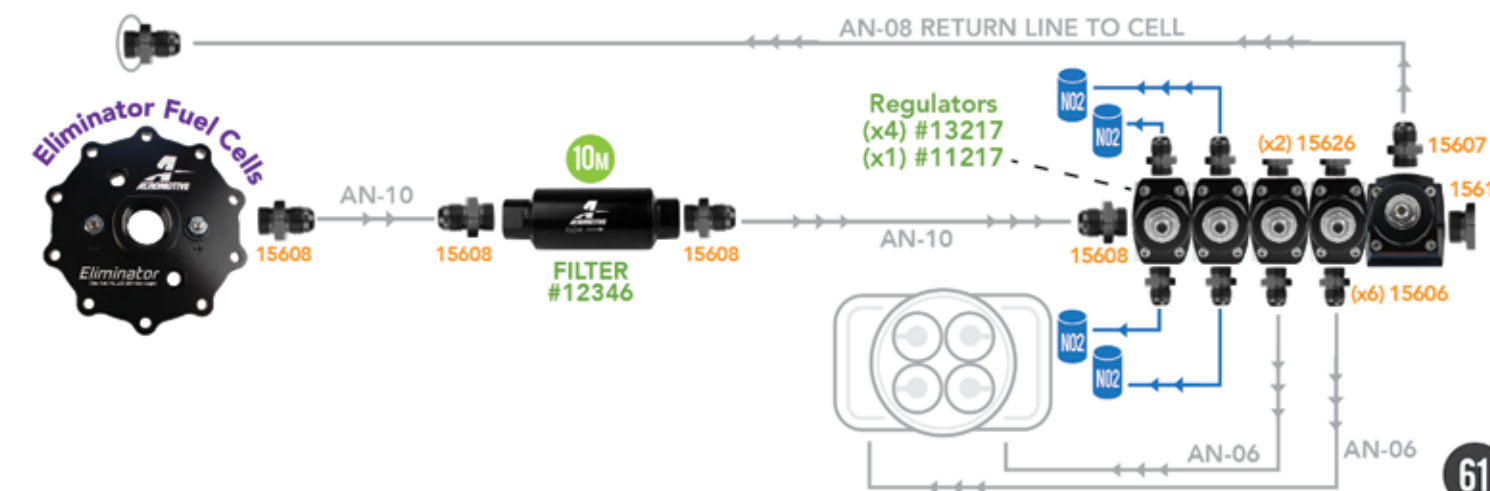

12 GPM Dual Fuel Rail Fuel Injected

*flywheel	Naturally Aspirated	Forced Induction
GAS	8,000hp	7,000hp
E85	5,600hp	4,900hp
Methanol	3,000hp	2,500hp

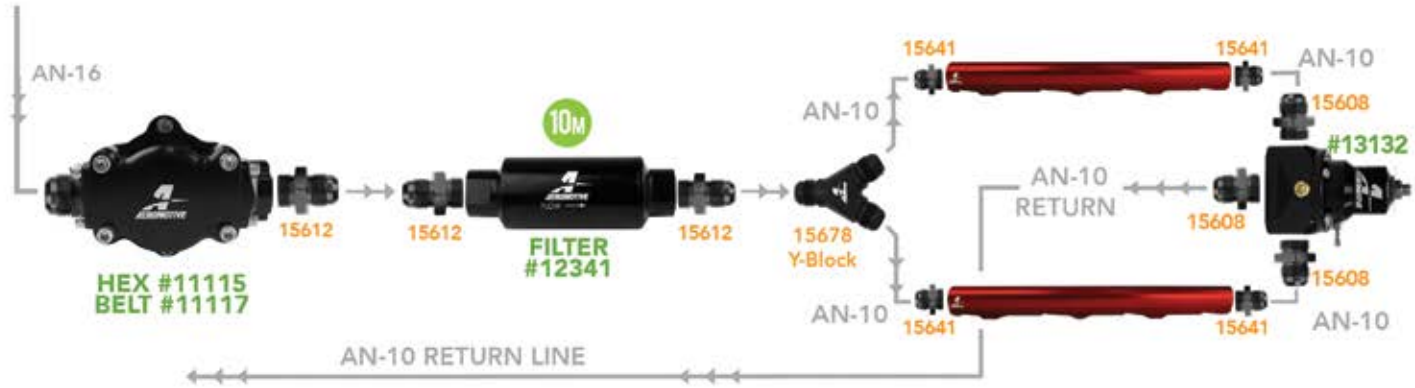

6 GPM Dual Feed Dual Carbureted

*flywheel	Naturally Aspirated	Forced Induction
GAS	4,000hp	3,600hp
E85	2,800hp	2,520hp
Methanol	1,800hp	1,500hp



6 GPM Dual Fuel Rail Fuel Injected

*flywheel	Naturally Aspirated	Forced Induction
GAS	4,000hp	3,600hp
E85	2,800hp	2,520hp
Methanol	1,800hp	1,500hp



6 GPM 2 Stage NO2 Fogger Carbureted

*flywheel	Naturally Aspirated	Forced Induction
GAS	4,000hp	3,600hp
E85	2,800hp	2,520hp
Methanol	1,800hp	1,500hp

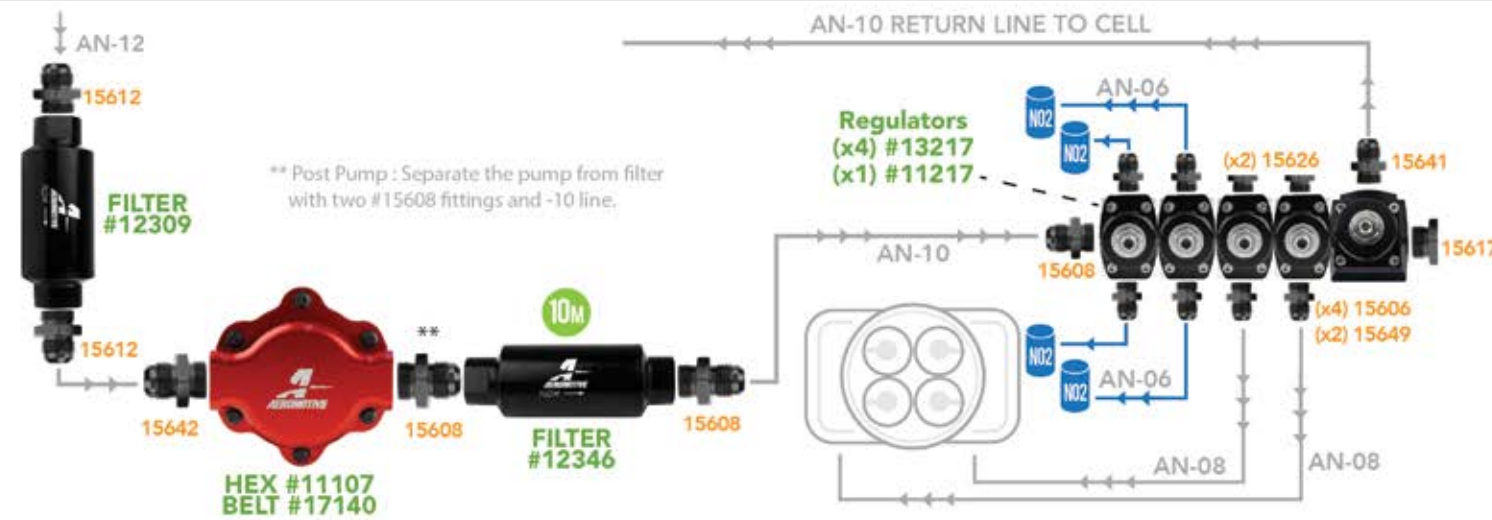

6 GPM Phantom Supported Fuel Injected

*flywheel	Naturally Aspirated	Forced Induction
GAS	4,000hp	3,600hp
E85	2,800hp	2,520hp
Methanol	1,800hp	1,500hp

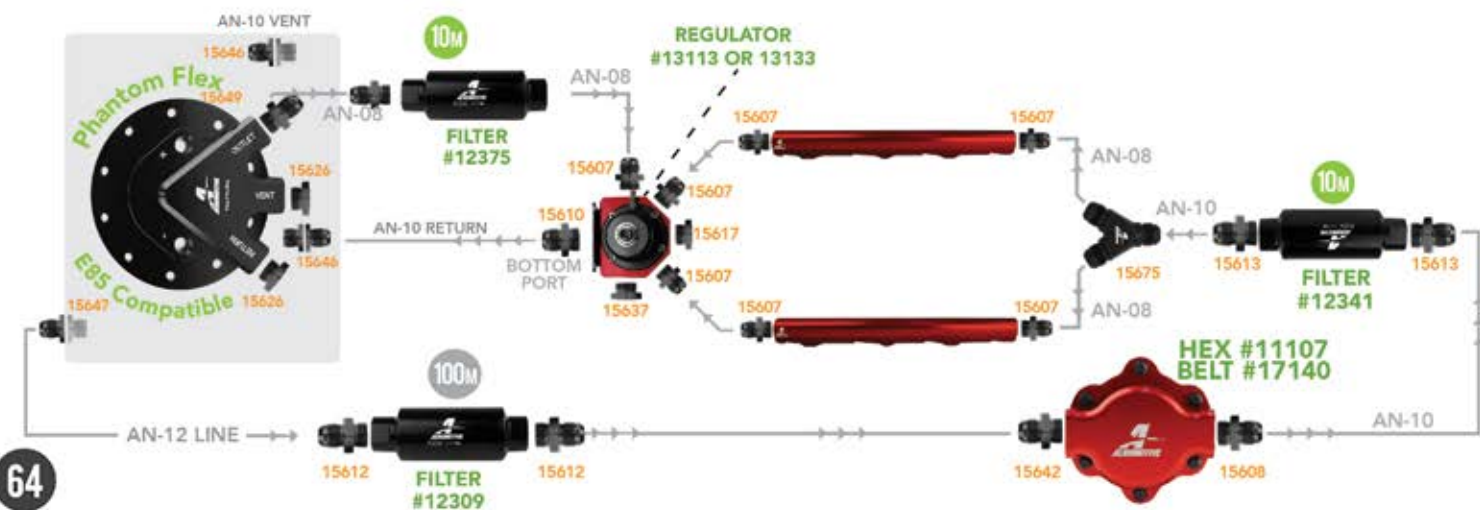

6 GPM Double Adjustable Carbureted

*flywheel	Naturally Aspirated	Forced Induction
GAS	4,000hp	3,600hp
E85	2,800hp	2,520hp
Methanol	1,800hp	1,500hp





913.647.7300

7805 Barton Street, Lenexa KS 66214

AEROMOTIVEINC.COM

 [Facebook.com/AeromotiveFuelSystems](https://www.facebook.com/AeromotiveFuelSystems)

 [@Aeromotive](https://www.instagram.com/Aeromotive)  [@AeromotiveFuel](https://www.twitter.com/AeromotiveFuel)